



ENGINEERS
AUSTRALIA

EHA MAGAZINE



Engineering Heritage Australia Magazine

ISSN 2206-0200 (Online)

September 2020
Volume 3 Number 6

EDITOR:

Margret Doring, FIEAust. CPEng. M.ICOMOS

The Engineering Heritage Australia Magazine is published by Engineers Australia's National Committee for Engineering Heritage. Statements made or opinions expressed in the Magazine are those of the authors and do not necessarily reflect the views of Engineers Australia.

Contact EHA by email at:

EHA@engineersaustralia.org.au

or visit the website at:

<https://www.engineersaustralia.org.au/Communities-And-Groups/Special-Interest-Groups/Engineering-Heritage-Australia>

Unsubscribe: If you do not wish to receive any further material from Engineering Heritage Australia, contact EHA at :

EHA@engineersaustralia.org.au

Subscribe: Readers who want to be added to the subscriber list can contact EHA via our email at :

EHA@engineersaustralia.org.au

Readers wishing to submit material for publication in the Engineering Heritage Australia Magazine, can contact the Editor via email at :

EHA@engineersaustralia.org.au

Cover Images:

Front: A train about to enter Werther Brücke Station on the Wuppertaler Schwebebahn in Germany on January 8th 1913.
Source: US Library of Congress
Photo via Wikimedia.

Back: The AWA Tower, at 45 York St., Sydney opposite Wynyard Park, seen from Marton Hall, at the other end of the Park.
Photo by Max Dupain, circa 1948.
Source: State Library of NSW - Ref.9587579

This is a free magazine covering stories and news items about industrial and engineering heritage in Australia and elsewhere. It is published online as a down-loadable PDF document for readers to view on screen or print their own copies. EA members and non-members on the EHA mailing lists will receive emails notifying them of new issues, with a link to the relevant Engineers Australia website page.

CONTENTS

Editorial	3
Winners of the 2019 Colin Crisp Awards	4
Connections	7
Sir Ernest Thomas Fisk	9
Anthony George Maldon Michell	18
Die Wuppertaler Schwebebahn	24

Not Quite the Latest News

The Ultimo Tramways Power Station in Sydney, now known as the Powerhouse Museum, or the Museum of Applied Arts & Sciences.

In the January 2019 issue of this magazine, I wrote a piece lamenting the then proposed sale and demolition of the Powerhouse Museum.

As the July 1st 2020 date for the proposed closure, and later emptying of the Museum buildings got closer and closer, and then passed, I despaired that anything could happen to save it. And then, on the morning of 4th July, came an email from an old friend in Sydney, who has been in the thick of the protest movement. The subject?

POWERHOUSE SAVED!

The Sydney Morning Herald announced: "Powerhouse backflip as Ultimo site saved by Berejiklian government. The Powerhouse Museum in Ultimo has been thrown an extraordinary 11th-hour lifeline and will not close but instead operate across two sites, including one in western Sydney." You can read all about it at:

<https://www.smh.com.au/politics/nsw/powerhouse-backflip-as-ultimo-site-saved-by-berejiklian-government-20200703-p558vn.html?fbclid=IwAR13Dyfs5wNgurr93GpzmuPXtGVKpaFZBE156y0q61ptgBAtrKvOPcKwJT4>

Editorial

Considering the note about the Powerhouse Museum (aka the Ultimo Tramways Power Station) on the previous page, perhaps my opening words here should have been “This is the Latest News” or “Stop Press”! On 10th September I received an email from Heritage NSW titled: *Listing on the State Heritage Register: Notice pursuant to 37(1)(a) of the Heritage Act 1977 (NSW) Item: Ultimo Power House Address: 500 Harris Street, Ultimo SHR no: 02045.*

I advise that the Minister responsible for Heritage, the Hon Don Harwin MLC has, on the recommendation of the Heritage Council of NSW, directed the listing of the above-mentioned heritage item on the State Heritage Register (SHR). The listing was published on 4 September 2020 in NSW Government Gazette No. 199. My question is, why didn't this happen years ago?

Stephen Phillip, who wrote the story about A.G.M. Michell and his famous thrust bearing, is a new writer to our pages. I asked him to tell me something about himself, and here is his slightly edited reply:

I am a mechanical engineer, and completed my degree at the University of Melbourne in 1987. I heard of Michell primarily from our lecturer in fluid mechanics (professor Peter Joubert) and also because we had a prototype crankless engine in the mechanical engineering department. In the early 2000's I became increasingly curious to learn more about Michell. Despite extensive searching I was unable to find a comprehensive biography, however over time I accumulated lots of snippets from his fascinating life. One day I decided to write his biography myself. Stephen's book, titled *What came out of the box - a biography of Anthony George Maldon Michell* is undergoing publication at present, and should be available for purchase soon.



Two men, two boys and a strange toy, from the 1902 movie – colourized version.

In telling my story of *Die Wuppertaler Schwebebahn*, which you can find at the end of this magazine, I wrote about how much I was helped by my Internet research, particularly in Wikimedia, to supplement my few usable photographs of the subject, taken nearly 30 years ago. And to refresh my memory of the trains, daughter Jessie pointed me to a Youtube movie she had found which showed the moving trains from various points along their route. Even better was another which took me for a ride in the driver's cabin. Magic! But then



The Schwebebahn dives under an arch of the pre-1914 Sonnborner Railway Bridge, from the 1902 movie.

another one that I never expected to see turned up via Facebook – a 1902 movie (Yes, 1902!) of the view from the driver's cabin – found in Germany and restored for MOMA. It's a gem. Find it at <https://youtu.be/2Ud1aZFE0fU>, but not now – I suggest you don't watch it until you have read the story (page 24) and looked at the modern videos it references. Instead, as a taster, here (above) are two screen shots from the 1902 movie.



Jessie keeps finding new and interesting topics for me on the internet and recently she sent me an email titled *Roy Doring*. Roy Doring was Jessie's great-uncle. She never met him, but she grew up with stories about him part of the family legends. Uncle Roy was an auto-electrician with a business in Kogarah, a southern suburb of Sydney. His



Roy Doring at the wheel of his Ford. Screenshot from the ABC film.

major preoccupation, for many years, was the promotion of electric cars. The email had a link to an ABC *Learn English* educational film made in 1968 and titled *An Electric Car*.¹ (see above) In it, Roy is driving a 1959 Ford Prefect, in which he had installed an electric motor and 13 batteries. This was weird! I never saw that car on the road, but I was taken to see it in store at the Powerhouse Museum a few years ago.² I first met Uncle Roy in 1961, when Carl and I visited him one day at the shop, and were taken for a ride in his 1914 Detroit Electric – obviously inherited from Grandma Duck – a smooth, silent ride in a comfortable seat. Apparently Roy had two Detroit Electrics, and one is now in a WA Museum.³ The other – the one I rode in – is somewhere else unknown, but a Doring cousin sent me an old photo of it recently. (See right) This car Roy used daily, driving to work, where he charged it, and to do the shopping.



1 <https://www.abc.net.au/education/learn-english/an-electric-car/12417404>

2 <https://maas.museum/inside-the-collection/2018/01/25/roy-dorings-1959-ford-prefect-and-the-museums-other-electric-cars/>

3 <https://rac.com.au/car-motoring/info/state-was-oldest-electric-car#:~:text=One%20of%20those%20early%20cars,and%20used%20throughout%20its%20life.>

The Winners of the 2019 Colin Crisp Awards

Introduction

Excellence in engineering heritage deserves recognition and Engineers Australia has two major awards to celebrate such achievements. These are the John Monash Medal and the Colin Crisp Awards. The Colin Crisp Award perpetuates the memory of Colin Crisp, who was a structural engineer well known for his work in the conservation of heritage structures. For an article about Colin Crisp in the June 2015 issue of this magazine – see: <https://www.engineersaustralia.org.au/Communities-And-Groups/Special-Interest-Groups/Engineering-Heritage-Australia/Previous-Magazines>

The Colin Crisp Award is given for excellence in:

- the conservation and recording of items of heritage significance, or
- recording engineering accomplishment and the development of technology, or
- education and raising awareness of engineering heritage.

The Awards are made every two years and entries are facilitated through Engineers Australia. Judging is then carried out by a committee within Engineering Heritage Australia (EHA), which in the case of the 2019 Awards was led by Owen Peake, a long-term member of and an active participant in EHA. For more about the Colin Crisp Awards (and the John Monash Medal) see: <https://www.engineersaustralia.org.au/Diversity-Awards> The Chair of EHA, Merv Lindsay, has announced the winners of the 2019 Colin Crisp Awards, and this article presents some information about the winners, who are:

- **Conservation Project:** Transport for New South Wales (formerly Roads and Maritime Services) for the restoration of the Barham-Koondrook Bridge.
- **Documentation Project:** William (Bill) Phippen OAM, for his book *The Hawkesbury River Railway Bridges*.
- **Highly Commended:** David Jehan, for his book *A History of Hudson Brothers, Carpenters, Engineers and Manufacturers 1866 to 1898*.

The Conservation Project – Restoration of the Barham-Koondrook Bridge ¹

The 2019 Colin Crisp Award for restoration works was made for the \$25 million restoration of the Barham-Koondrook Bridge, over the Murray River, about 90 km north west of Echuca. Transport for NSW (TfNSW), in partnership with Regional Roads Victoria, recognised the bridge's significant heritage value, with restoration work carried out in stages between 2012 and 2019. This restoration (or reconstruction) will ensure that the iconic bridge continues to meet current and future vehicle loads and volumes.

To place this bridge in its historical context, the proposal for the Barham-Koondrook Bridge was greeted with enthusiasm from the locals on both sides of the Murray River. The Barham-Koondrook Bridge was a key component in the linking of the two former colonies (and later, states) of NSW and Victoria. The opening ceremony attracted the Public Works Ministers from both NSW and Victoria, as well as and for the first time, a Federal Minister in the person of the new Postmaster-General, Sydney Smith. However, it was the NSW Minister for Public Works, Charles Lee, who put the new bridge into its engineering context with his rather poetic statement: *It is only necessary to lay a plank from stone to stone to evolve the principles of piers and arches, which have been brought to such a point of exact science in our own days.*



The Barham Bridge after restoration was completed. Photo source: Transport for NSW.

¹ Some discussion of the project can be found at <https://www.rms.nsw.gov.au/projects/barham-bridge/index.html>

The Winners of the 2019 Colin Crisp Awards

Restoration of the Barham-Koondrook Bridge (Continued)

In our days, some 110 years on, this scientific (or more correctly, engineering) significance still remains strong. Listed on both the NSW and Victorian State Heritage registers, the 1904 bridge is one of the oldest operational lift-span bridges across the Murray River. Further, the Barham-Koondrook Bridge is associated with respected engineers E.M. de Burgh and John Monash. E.M. de Burgh's design incorporated innovative engineering science, allowing this style of timber truss bridge – named after the eminent engineer – to take far heavier loads than existed at the time the bridge was built.

The restoration/reconstruction work included: replacing the bridge abutments, approach spans, piers, timber truss spans and deck; painting and mechanically upgrading the lift span towers; building a new external walkway and removing the internal walkway; installing lighting and a lift span maintenance ladder; and strengthening some structural elements to allow heavier truck loads.

Skilled TfNSW bridge carpenters carried out truss fabrication and assembly. Significant work was required, including installing a temporary crossing to allow the community to continue crossing the river while the bridge was closed during restoration work, eliminating the need for working in live traffic, and avoiding delays and disruptions. A containment area was built to avoid polluting the river during paint removal, while a novel “Lift and Skate” technique² was used to move the truss spans into place.

A Heritage Interpretation Plan was developed and carried out, incorporating salvage and re-use of elements from the old bridge to provide examples of bridge fabric for people to see, touch and feel. The community now has a fully functioning lift-span bridge that is stronger, lower maintenance, more reliable and continues to be a local icon. This was a restoration project that is fully worthy of the Colin Crisp Award.

The Documentation Project – The Hawkesbury River Railway Bridges

The 2019 Colin Crisp Award for documentation was bestowed on William (Bill) Phippen OAM, a notable railway author and speaker, for his book *The Hawkesbury River Railway Bridges*, which was published by the Australian Railway Historical Society, NSW Division (ARHSnsw) in 2018. Bill's book covers the history of the two bridges at this site – the original one opened in 1889 and since demolished, and the replacement bridge completed in 1946. The Colin Crisp Award recognises that this book preserves, within NSW's rich rail heritage, the history of these two Hawkesbury River Railway bridges, ensuring that the important role they played in the development of NSW and its railways will always be remembered.

In 2010 the book sprang from the locating of official New South Wales Government Railways (NSWGR) photo albums at the Australian Railway Historical Society NSW and the NSW State Archives and Records, together with the original American engineer's photo albums in the Library of Congress (Washington DC) in 2014. The book delivers a detailed explanation of the projects, covering two important engineering structures that, to date, have been largely undocumented.

The Hawkesbury River Railway Bridges are certainly a worthy topic for a book, with their respective histories across two ages, their engineering significance and their ongoing importance to the NSW rail network. At the public launch of the book on 18 May 2018, at the bridge site, Sydney Trains' Executive Director Engineering and Maintenance, Stuart Mills, said that: *The Hawkesbury River Bridge is to Sydney Trains what the Sydney Harbour Bridge is to the Roads and Maritime Services.*³

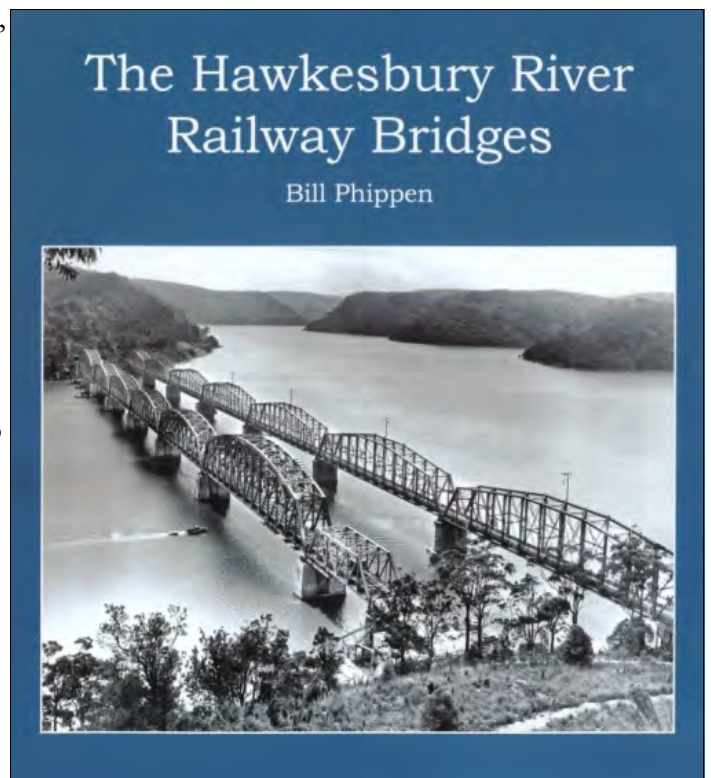

The jacket cover of Bill Phippen's book.

This photo, taken in 1946, shows the nearly completed new bridge at left and the soon to be demolished 1889 bridge at right.

² The technique is described in two videos at <https://www.rms.nsw.gov.au/projects/barham-bridge/index.html>

³ NSW Roads and Maritime Services has recently changed its name to Transport for New South Wales (TfNSW).

The Winners of the 2019 Colin Crisp Awards

The Hawkesbury River Railway Bridges (Continued)

So, why are these bridges so important? The first bridge, built by an American contractor in 1889, replaced a slow cross-river ferry transfer, and opened up the artery of regional development with the speed and convenience of rail from Sydney to Newcastle and further North. The bridge, at the time the world's third largest, completed the inter-colonial rail link between Brisbane, Sydney and Melbourne, thus bringing the reality of Federation closer. The second bridge, opened in 1946, was a triumph of wartime ingenuity over adversity and, at the time, was one of the greatest examples of technical endeavour by the NSW Railways. Despite severe shortages of labour and materials, the replacement bridge was entirely designed, fabricated and erected by the NSW Railways' own staff - a feat unimaginable in 2020.

The current and former Hawkesbury River Rail Bridges have State Heritage significance on the NSW Heritage Register, as Item 1040. They form a railway precinct of exceptional significance, demonstrating high levels of engineering achievement and the changes in railway technology in NSW in the period between the 1880s and 1970s.

With contemporary sketches and photographs of the first bridge and the extensive photos and diary logs of the second, every aspect of the operations from inception of the first bridge through to the present day, has provided a definitive public engineering resource as a story that needed to be told. This book provides the opportunity to fully appreciate the work that was required to complete engineering projects of this scale in two previous periods of engineering history. The engineering excellence of the original work shines out from the author's coalescing of the source material into a work that can be appreciated by engineers, railway aficionados and the general public, who can now from one source, gain an excellent documented explanation on the construction of these two historically significant bridges and their relevance to NSW society and history. This book will remain a testimony to the engineers and workers that made it all possible, available as a definitive resource to all those interested in the engineering construction of these two bridges.⁴

A Highly Commended Project – A History of Hudson Brothers

In 2019 professional engineer and author David Jehan published a history of the Sydney engineering firm *Hudson Brothers – Carpenters, Engineers and Manufacturers: 1866 to 1898*. This book was Highly Commended in the 2019 Colin Crisp Awards.

The Hudson business was founded when Plymouth cabinet-maker William Henry Hudson, arrived in Sydney in 1846 with his family and started a joinery business in Redfern, a suburb of Sydney. This became known as 'Hudson & Sons'. Hudson became one of the main builders in Sydney providing timberwork to many notable buildings including the Great Hall of Sydney University.

Twenty years later, in 1866, William Henry retired and left the business to his three sons Henry, Robert and William. The firm now took on the new name of 'Hudson Brothers' and a new direction, and this story is set out in David Jehan's book. Under the leadership of Henry Hudson, the firm imported the latest woodworking machinery from America and rebuilt the original Redfern joinery shop as the 'Steam Joinery Works'. They also operated their own sawmills in the Myall Lakes district of NSW and the suburb of Pyrmont – now part of Central Sydney. They also had depots in various NSW country towns such as Hill End, a famous Gold Rush town. Hudson Brothers introduced much new technology into Australia from the USA. They were also a major supplier of agricultural equipment including ploughs, chaff cutters, horse works, windmills, etc.

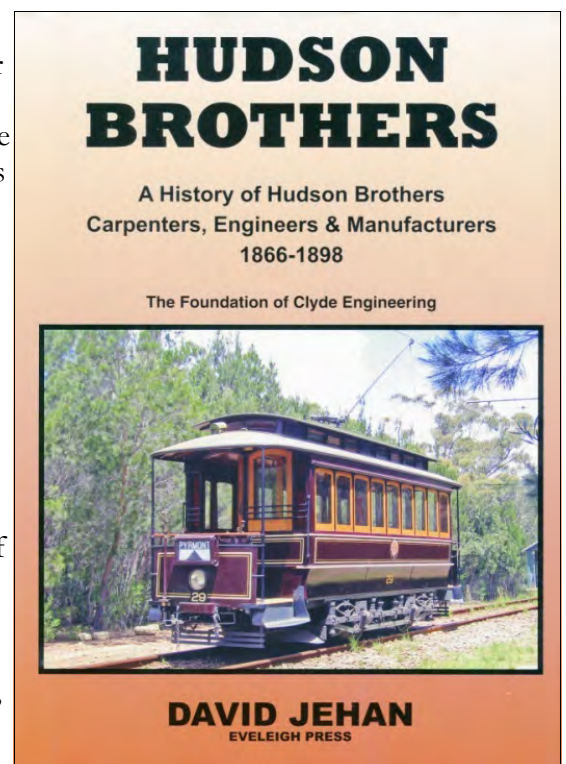

The jacket cover of David Jehan's book.

4 A review of the book can be found in the September 2018 issue of the EHA Magazine. Find it at: https://www.engineersaustralia.org.au/sites/default/files/resource-files/2018-09/EHA_Magazine_Vol2_No9_September_12018.pdf

The Winners of the 2019 Colin Crisp Awards

A History of Hudson Brothers (Continued)

The brothers moved into railway rolling stock manufacture after the collapse of PN Russell and Co. and greatly expanded their Redfern works. Their success required further growth resulting in the company building a massive industrial complex at Granville, in western Sydney, and acquiring a third plant in Wickham, an inner suburb of Newcastle. The firm was incorporated as Hudson Brothers Limited in 1882 and became the major rolling stock manufacturer at the time. Thousands of goods wagons, passenger carriages and tramcar trailers were built for the NSW Railways. These served the rapidly expanding NSW railway network, which increased about seven-fold during the period covered by this book, to around 5,000 km of rail.

Hudson Brothers Limited would ultimately become the iconic Clyde Engineering Company in 1898, but that is another story to be told. The timber supply business was split off from the engineering business in 1886 and survives nominally as Hudson Building Supplies, a name that Sydney readers may well identify with.

David Jehan has provided a comprehensive account of the Hudson brothers and their firm's role in the development of manufacturing and engineering in Australia in the late 19th Century, and its contribution to the growth of our country. Thus, his book really merits the Highly Commended Colin Crisp Award, as it is increasingly important to document these achievements and contributions to Australia before their history is lost.

It would seem appropriate to record that in 2019 David Jehan was awarded the Engineers Australia John Monash Medal for his outstanding contribution to engineering heritage for more than 30 years. This medal is given to an individual who has made an outstanding contribution to the cause of engineering heritage over a considerable time. Nominations were received from across Australia. David was described as being a passionate advocate for recording, preserving and celebrating engineering heritage, for leadership in the profession and tireless effort in raising public awareness of the work of engineers and the importance of engineering to the community:

From Frank Johnson, Chair of EH Sydney.

Connections

Books by the Colin Crisp Award Winners

The Colin Crisp Award winner *The Hawkesbury River Railway Bridges* book, by Bill Phippen, and the Highly Commended book *HUDSON BROTHERS – A History of Hudson Brothers, Carpenters, Engineers & Manufacturers, 1866-1898*, by David Jehan, are available from the Australian Railway Historical Society NSW (ARHSnsw) Bookshops at the Grand Concourse, Central Railway Station, Sydney, and at 5 Henderson Road, Alexandria, or on-line through <https://arhsnsw.com.au/shop/>



The images are of the authors – Bill Phippen at left, from ARHSnsw and David Jehan above right, from LinkedIn. Readers might like to know that both men have written other railway related books.

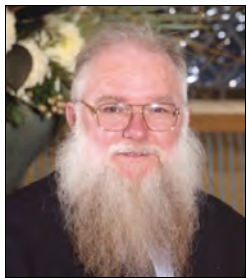

Bill Phippen has authored:

By Muscle of Man and Horse - Building the Railway Under Sydney: 1916 - 1932, pub. ARHSnsw 2018.
The Timber Truss Railway Bridges of New South Wales, published in 2020 and available from ARHSnsw, or the author at billhippen@telstra.com; and *From Eddy Avenue to Menin Gate: The Great Sydney Station Honour Board* (with Dugald Black, Richard Mathews and Lily Somer) about the lives of the 1219 railway & tramway employees named on it, pub. ARHSnsw 2019.

David Jehan's books include: *Rack Railways of Australia*, published in 1997; *Men, Steel and Rails: The Operations Of The BHP Newcastle Rail System From The Introduction of Diesel Traction to the Closure of Primary Steelmaking in 1999*, Pub. 1999 by BHP; *Shays, Crabs and Phosphate: A History of the Railways of Christmas Island, Indian Ocean*, Pub. 2008 by the Light Railway Research Society of Australia; *A History of Tulloch, Engineers and Manufacturers Pyrmont & Rhodes 1883-1974*, Pub. Eveleigh Press, 2015.

All the above books (except *From Eddy Avenue to Menin Gate*;) are available from the ARHSnsw bookshops or online from: <https://arhsnsw.com.au/shop/>

Connections

Conferences and other gatherings

I have heard recently that the Australasian Heritage Conference that was to be held in New Zealand this year, and was postponed, like so many other functions, will now be held (we hope) in Dunedin NZ from the 14th to the 17th of November 2021. More about this to come in the next issue of this magazine, but in the meantime, go to <https://www.engineeringnz.org/programmes/heritage/australasian-engineering-heritage-conference-2020/> to find out more – but please don't ask me why it says 2020 on the link. Perhaps that will be changed before long, and you'll have to Google the Conference. The Call for Papers ends on 5th April 2021.

I was looking forward to attending the Victorian Engineers Country Weekend, which was to be held in and around the Nagambie area in October this year. It, also, had to be postponed. It is now to be held over the weekend of 15th to 17th of October 2021. Visits to several important engineering heritage places – Kirwan's Bridge, Goulburn Weir, Waranga Basin, and more – will be on the schedule. Martin Duke, of the organising group wrote: *We will continue to work on this event, to ensure it will be a great time to come together safely, in interesting surrounds, with great sights to see. We are hoping you are well and staying safe and we look forward to seeing you all in 2021.* If any of our readers would like to know more, please email David Eltringham <djelt@bigpond.com>

Australian “Engineering Icons”

A reader sent me this link – <https://www.engineeringicons.org.au/engineering-icons/australian/index.html?> These web pages are part of the Warren Centre, Sydney University website. They contain a wealth of information about the chosen icons, and if you can go back to the Warren Centre Home Page, have a look at the *Clever Engineering* pages for more of interest. Except for the Sydney Harbour Bridge, the *Engineering Icons* are not exactly Engineering Heritage, but who knows? Give them time!

Cleaning Historic Surfaces

Ken McInnes always keeps his ear to the ground (metaphorically speaking!) and often sends us useful information. This time it's *Support for Heritage During the Coronavirus Pandemic* from Historic England. Ken says: I thought it worthwhile sharing this link to a guideline from Historic England on Cleaning Historic Surfaces: *Some cleaning methods may cause lasting damage to historic surfaces. Our guidance can help you disinfect surfaces while preserving historic materials.* Go to: <https://historicengland.org.uk/coronavirus/historic-places/cleaning-historic-surfaces/> I thought it was pertinent to pass this on, particularly considering that a query came up at a meeting I attended recently asking if anyone knew how to go about cleaning the pylons of the Sydney Harbour Bridge.

Mt Morgan Mine

Back in the January 2018 issue of EHA Magazine, there was a substantial story about *Moving the Golden Ore of Mount Morgan*. The author, Dr Ray Boyle, who worked at the mine for many years, recently sent me an email with a link to a film saying: *I came across this film made on the handover of the Mount Morgan Mine to the Qld Mines Dept on the closure of the mine. It is quite interesting. It includes a lot of material we used in our Centenary film “The Reluctant Mountain” made in 1982.* The Youtube link he sent is from NZFP Resources Ltd Mount Morgan July 1993

at <https://www.youtube.com/watch?v=ByLZXxeu5Bo&feature=share>

I did a hunt for the 1982 film, with no success, but two short videos – *Our World by Drone in 4K - Mount Morgan Mine, QLD, Australia* at <https://www.youtube.com/watch?v=zr9ASykZfXc>

and *Mount Morgan, from Gold Coast Drone Vision* at https://www.youtube.com/watch?v=_mK2WGT5K-Y both add a different perspective to the picture of the mine shown in NZFP's film.

WWII at Home – Response, Reflection & Rejuvenation

This exhibition, at <https://wwiiathome.com.au/> from the National Trust of Australia (Victoria) features: *18 sites of significance that represent the transformative impact the Second World War had on Victoria. Explore our response to the war effort, sites of reflection that honour the sacrifice of war, and places that embody the post-war rejuvenation that was the birth of modern Australia.* The sections about the Walsh St House, the Olympic Pool and ICI House were the most interesting to me, featuring a couple of old friends, and with beautiful photographs by Wolfgang Sievers.

After the War was Over

Many of us have been reflecting recently on the end of WWII, and 15th August 1945, VP Day (always known to me as VJ Day!), and going through some old emails I came across this collection of “After the War” photos from *The Atlantic*: <http://www.theatlantic.com/infocus/2011/10/world-war-ii-after-the-war/100180/> Worth a look.

Sir Ernest Thomas Fisk (1885 - 1965)

Australia's Pioneer Real Radio Man

By Frank Johnson

Introduction

These days when one thinks of a “radio man”, the average person would probably think of one of the so-called celebrities, shock jocks and cash-for-comment broadcasters who have made a name for themselves in some circles on commercial radio stations across Australia. However, these people would have nowhere to peddle their often strongly held views, advertisements, self-promotions, etc., if it were not for the **real** celebrity, and pioneer of radio in Australia – Sir Ernest Thomas Fisk.

Fisk was responsible for the first radio transmission from the United Kingdom to Australia on the 22nd of September 1918, and then played a key role in the founding of Amalgamated Wireless Australasia Pty Ltd (AWA), our country's first radio company. Beyond these achievements, he was a man of vision, coupled with a real drive, natural inquisitiveness, determination and business sense. Unusually for an engineer, Fisk also lived out a theosophist philosophy, so he had a really wide-ranging mind. But how many people of the 21st Century have heard of this remarkable engineer?

I first came across Sir Ernest Fisk when I was a young lad living in Roseville, on Sydney's North Shore, in the 1950s. We would see this elderly gentleman riding his bike near our place and my mother pointed out to me that he was Sir Ernest Fisk. Obviously, in those days he was still a household name in Australia for his work in the development of radio and it would be a shame if his notable achievements were lost to current generations. Hence this story.



Sir Ernest Fisk n.d. (after 1937) by unknown. Collection: National Portrait Gallery, Australia.

Fisk's Early Life

Like many of the early engineers in Australia, Fisk was an Englishman. He was born 6th August 1886, at Sunbury-on-Thames, Middlesex, England. It would seem that the English educational system of the time did not suit young Ernest, for he left school at about 13 to work in a factory and then in a railway station bookstall. Perhaps the reading matter available in this bookstall widened his imagination and encouraged him to look elsewhere. Fisk went on to ‘graduate in engineering’¹ in the works of Frederick Walton, the inventor of Linoleum.

Fisk also worked for a period as a clerk in the Post Office at Sandhurst in Berkshire and this may have been his turning point. It was here that his inquisitive nature led him to learn Morse Code. This was a standard means of communication at that time, having been in use for some 60 years after its invention in the 1830s by Samuel Morse, for electric telegraphy (over wires), and most commonly used by the Post Office and the Railways.

Ernest Fisk and Guglielmo Marconi

Fisk's work in the British Post Office was to change with the arrival of the Italian inventor and engineer Guglielmo Marconi. After Marconi arrived in England in 1896, backers such as the Post Office supported him and he developed, demonstrated and marketed the first successful long-distance wireless telegraph, broadcasting the first transatlantic radio signal in 1901. Fisk embraced this new means of communication and in 1905 he joined Marconi as a radio operator and then became qualified as a radio engineer through his work for the Marconi company. Fisk quickly demonstrated his higher-level skills, for he was sent to the United States, Canada and Australia to demonstrate Marconi's products.



Image Left:

Fisk's colleague and associate for many years, the Marchese Guglielmo Marconi. Their association ended with Marconi's death in 1937. This image comes from a 1935 AWA booklet memorialising the 1918 first radio transmission from Marconi in the United Kingdom to Fisk in Australia.

1 Quoted from <http://adb.anu.edu.au/biography/fisk-sir-ernest-thomas-6177> [The University of the Factory Floor? Ed.]

Sir Ernest Thomas Fisk

In fact, Fisk's work with Marconi took him to the extremes of the earth, from the tropics to the Arctic. In 1909 he went there to test the possibilities of wireless communication for the Newfoundland seal hunting fleet. This was one of many "impossible" experiments which he carried through successfully.

Fisk first visited Australia in mid-1910 in the SS *Otranto* to demonstrate Marconi's apparatus for the Orient Steam Navigation Co. At that time, wireless was still largely the preserve of amateur enthusiasts. Aboard the *Otranto*, Fisk established communication with HMAS *Powerful*, lying in Sydney Harbour, when the *Otranto* was two days off Fremantle. The *Otranto's* wireless theoretically had a limited range of 200 miles. Beyond that it couldn't go, but Fisk sent his messages 2000 miles. This was an early example of Fisk's ability to really test and push the boundaries of wireless engineering.

Image Right: Ernest T. Fisk, c.1911, photographed when he came from England to represent the London-based Marconi companies in Australia and New Zealand. Fisk wears a uniform and holds a cap with a peak surmounted by an 'M' in a laurel wreath. Source: ABC RN website, original held by J. Fisk, Canberra.



Australia and AWA

Perhaps Fisk was impressed with the potential for wireless in Australia, for in 1911 he returned, as Marconi's Resident Engineer. This was fortuitous, for at this time the Australian Government was just beginning to establish radio communications. After some contractual issues with competing patents between Marconi and the German company Telefunken, the Government in 1913 formed a new company, Amalgamated Wireless (Australasia) Ltd – or AWA as it became known over the years. AWA had exclusive rights throughout Australasia to the patents, 'present and future', for both Marconi and Telefunken. Fisk was a founding director of AWA, with the roles of General and Technical Manager. In 1916 he became Managing Director and in 1932 was made AWA Chairman.

World War 1

Fisk was always keen on Australia developing her own radio manufacturing industry, but between 1911 and the outbreak of the Great War in July 1914, little happened in Australian radio development. However, with the dangers of the war and German presence in the Pacific, the radio industry developed almost overnight. AWA erected a land station on Garden Island (a Naval Depot in Sydney Harbour) in four days, and six stations were shipped (with Fisk) aboard HMAS *Melbourne* for "unknown destinations". These destinations turned out to be New Guinea (then a German Colony) and New Caledonia, and the staff sent with the young radio engineer was responsible for capturing the German radio stations in New Guinea, while the establishment of watching stations saved the East Coast of Australia from attacks by enemy ships.

This early establishment of wireless facilities did prove very timely, for the warships guarding the first convoy of troops from Australia to Europe were warned by a dramatic five-word wireless message from Cocos Island, *Strange warship approaching the islands*. This warship turned out to be the German cruiser *Emden*, which was sunk by the Australian cruiser *Sydney* in an epic battle on November 9, 1914 – just ten weeks after WW1 broke out.

First radio transmission United Kingdom to Australia

Perhaps the high point of Fisk's and AWA's contributions to the war effort came with the first radio transmission (in Morse Code) between the UK and Australia in September 1918. Before then, all telegraphic communications between the two countries had been via submarine cable, but during WW1 the Government became very concerned that this cable could be cut by German forces, thus severing this link that was vital to Australia for defence, economic and political purposes.

Image Right: A plaque on the 1935 memorial to the 1918 1st radio transmission UK to Australia. The memorial is outside Fisk's former Wahroonga home where he set up the receiving station for the transmission. Source: Frank Johnson.



Sir Ernest Thomas Fisk



A recent photo Marconi's Waunfawr Transmitter site on top of Cefn-du in Wales. It was once surrounded by tall steel masts, and their concrete footings remain.

Source: Graham Stephen, August 14, 2010, in GEOTOPOI.wordpress.com.

and forced back the legions of the enemy, filled with greater admiration than ever for these glorious men and more convinced than ever that it is the duty of their fellow-citizens to keep these magnificent battalions up to their full strength. W.M. Hughes, Prime Minister.

Coincidentally, for an article in Engineering Heritage Australia Magazine, these troops that PM Hughes commended so highly were led by another notable Australian Engineer and probably its most famous military officer, General Sir John Monash.

The second message was sent at 1.25 pm Sydney time (3.25am Greenwich Mean Time), from the Minister of the Navy Joseph Cook who had accompanied Hughes on the trip to England. His last sentence refers in part to a problem selling Australian farm produce to the UK.

Royal Australian Navy is magnificently bearing its part in the great struggle. Spirit of sailors and soldiers alike is beyond praise. Recent hard fighting brilliantly successful but makes reinforcements imperative. Australia hardly realises the wonderful reputation which our men have won. Every effort being constantly made here to dispose of Australia's surplus products. Joseph Cook, Minister for Navy.

While Marconi and his radio engineers were no doubt on site in Wales (and Fisk and his team in Wahroonga), our two politicians were not. Their messages had been sent to the transmitting station the previous day, leaving the politicians, no doubt, to sleep through this occasion in their comfortable hotel beds, waking some hours later to

take as much of the credit as possible.



Fisk described the receipt of this message as one of the greatest thrills of his life and it was certainly a day of tremendous importance for Australia, for it marked the successful conclusion of a long series of researches and became the foundation of all the long-distance wireless telegraph, wireless telephone and broadcasting services which followed. For a country as remote as Australia, this was certainly a critical necessity and benefit. A monument outside his house was unveiled in 1935 to commemorate this significant location and event and that monument still stands in 2020.

Image Left: Ernest Fisk photographed in his own receiving station at Wahroonga while receiving the first radio messages sent from the UK, 22nd September 1918. This image is an extract from a framed certificate published by AWA to record the occasion. The photo is probably by Sam Hood.

Source: www.otva.com/100-year-anniversary22-september-2018-

This was another cooperative effort between Marconi and Fisk, albeit at a great distance, with Marconi in the UK, and Fisk in Sydney. Marconi set up a long wave station in Carnarvon, Wales, for the initial broadcast to Australia. At the other end, Fisk set up a receiver at his own house, *Lucania*, in Wahroonga, on Sydney's leafy North Shore. Fisk had designed his own apparatus, and it was manufactured in Sydney by the staff of AWA. Thus, on 22 September 1918, the first direct radio broadcast was made between the two countries. In this first direct radio transmission, there were actually two messages, the first at 1.15 pm Sydney time (3.15 am Greenwich Mean Time) by Prime Minister Billy Hughes:

I have just returned from a visit to the battlefields where the glorious valour and dash of the Australian troops saved Amiens

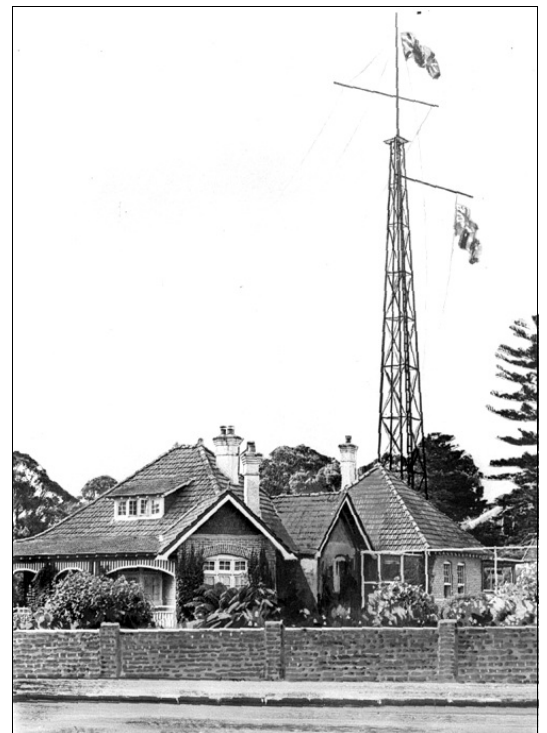

Radio mast and Ernest Fisk's home 'Lucania' at Wahroonga in Sydney. Photo: Sam Hood, c1918, State Library NSW

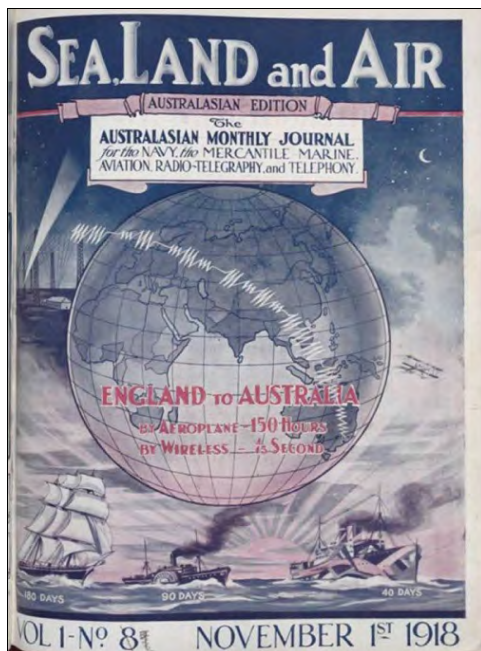

Sir Ernest Thomas Fisk

Further, this first successful radio transmission from England to Australia was noted in the November 1st, 1918 issue of *Sea, Land and Air*, the journal of the Wireless Institute of Australia. As an aside, it is interesting that *Air* is included, for it was only in 1903 that the Wright Brothers made the first controlled power flight, with the first Australian flight being in 1910, and already aviation was being linked with radio-telegraphy and telephony.

Image Left: This cover of *Sea, Land and Air* made some interesting comparisons of the relative times to traverse the distance between England and Australia: Sailing ship – 180 days; Steam Ship – 90 days; War ship – 40 days; Aeroplane – 150 hours; Wireless – 1/15th of a second.

Source: Not Recorded, but probably the State Library of NSW

The world was certainly changing, and Fisk was driving this change!

1927 – Shortwave Beam Wireless

One of Fisk's greatest achievements was the establishment of a Beam Wireless service in Morse Code. This was wireless in a directional beam rather than broadcast. He had been working on his Beam Wireless experiments for some years before the opening of the service in 1927, and in 1921 he had been much encouraged when General Smuts, Prime Minister of South Africa, asked him to discuss his experiments in Cape Town. They had met during the Imperial Conference of 1921, when Fisk was an adviser to Mr. W. M. Hughes, then Prime Minister of Australia. South Africa, like other countries, was doubtful of this scheme for wireless communications over long distances, but after their discussion, Smuts shook Fisk's hand, saying *I'm all with you.*² India soon followed South Africa's active encouragement, and despite almost overwhelming pressure from experts who ridiculed the scheme, Fisk went ahead with it, culminating in the first beam wireless communication between Australia and England in January 1927.³ Although the scheme was entirely new – commercially, technically, scientifically and on the operating side – it was carried through successfully, and with a 100 per cent Australian team.

Beam services provide the longest and fastest telegraphic communications in the world. They go at the rate of 186,000 miles per second and, according to a contemporary report: . . . *put a girdle round the earth in less time than it takes a Melbourne Cup winner to get into his stride. Before the service opened, the previous cable charge had been 5/- a word. AWA Beam service opened at 1/8 a word. Rates today are even cheaper (1/3 a word for full rate) and press cables (telling the world to Australia, telling Australia to the world) were now only one penny a word.*⁴

The inauguration of the Beam Wireless service was of tremendous importance for Australia, for it marked the successful conclusion of a long series of researches and the foundation of all the long-distance wireless telegraph, wireless telephone and broadcasting services which, from 1927, linked Australia with the rest of the world. This enabled any telephone subscriber in Australia to speak to any one of more than 35 million telephone subscribers in other parts of the world.⁵



Image Right & Above: This rather fanciful bird's-eye view painting of the former Australian Beam Wireless Transmitting Station at Ballan, west of Melbourne, was the only image found which showed the array of transmission towers originally on the site. This is the place where the first Beam Wireless communication between UK and Australia took place. Later, the area was renamed Fiskville.

Source: Victorian Heritage Database.

² *The West Wyalong Advocate*, Monday 3 January 1944, p3.

³ *Direct communication between Melbourne and London was established last night by means of beam wireless. Mr. ET Fisk, of the board of directors of Amalgamated Wireless (Australasia) Ltd., stated that he had had a long talk by Morse code from the Central Telegraph Office with Signor Marconi in London (Daily Telegraph Sydney, Monday 31 January 1927).* [Presumably the Central Telegraph Office must have been the Melbourne GPO in Bourke St.]

⁴ *The West Wyalong Advocate*, Monday 3 January 1944, p3. [5/- = 5 shillings = 60 pence; 1/8 = 1 shilling & 8 pence, etc.]

⁵ *Ibid.*

Sir Ernest Thomas Fisk

AWA Manufacturing between WW1 and WW2

In 1922 the government increased the new company's capital and became its majority shareholder. Thus, Fisk's ground-breaking radio communication of 1918 had now become a fully commercial enterprise. It was the principal Australian wireless technology and manufacturing concern, so in 1926, when the Australian Government needed a direct radio service with the UK, it commissioned AWA to create a service. Under Ernest Fisk, AWA substantially built up its engineering technology and manufacturing after WW1. Taking 1931 as an example, the following achievements were noted:⁶

- It created a record in the number of radio broadcast receivers manufactured in Australia. This was due to the over-whelming advantages of the new all-electric receiver, with its improved quality of reproduction.
- AWA completed negotiations for the manufacture of wireless valve manufacture in Australia, including the rights to research experience of some of the largest manufacturers in the world.
- AWA staff were sent overseas for training and experience, noting that valve manufacture would also have considerable importance in defence considerations for Australia.
- A new overseas broadcasting service was established, reaching such diverse locations in the world as Borneo, China, Alaska, New York, England and Central Africa.
- Wireless equipment was installed in Port Moresby, allowing a direct service between there and Sydney.
- Extensions were made to the Radiophone Service to all parts of Italy (including the Vatican State), Romania, Lithuania and Latvia, the Argentine, Uruguay, Chile and Brazil. It was reported that a telephone conversation was carried on from a telephone booth in Circular Quay with a subscriber in Chile, South America, a distance of 17,000 miles (about 27,000 kilometres).



The AWA factory in Ashfield.

Source unknown.

1931 also saw the construction and opening of AWA's new manufacturing facility at Ashfield in Sydney – all 75,000 square feet of floor space (about 7,000 square metres) on a four-acre (about 16,000 square metres) site. Fisk's hand in the new facility is quite clear from the site to factory floor ratio over 2 to 1, which implies a lot of open space. In his younger days Fisk had a strong interest in landscape garden design and AWA promoted these new works at Ashfield as *An Australian Factory in an Australian Garden*. Under Fisk's instructions, the Ashfield facility was designed on modern lines to provide brightness and comfort for the workers, and it also included a cafeteria, tennis courts and even a dance floor for the AWA employees. One cannot help but be impressed by the strength of Fisk's character (and his concern for his employees).

The Radiolette

Under Fisk, AWA's range of products covered both the industrial/commercial and the domestic markets with great success. In the domestic market, Fisk was

obviously well aware of customer demands and competition, with the development of what has been termed *Fisk's Radiolette*. Radio broadcasting had started in Australia in 1923, and by 1929 some 310,000 listeners had radio sets. AWA's domestic radio set, the *Radiola*, attracted a great deal of attention and sales, but there was competition developing. The *Grafton Daily Examiner* in regional NSW reported in December 1933: *Too long has the radio trade been engaged in making and selling the cheapest of unknown articles. There are far too many lines on the market which are made without the aid of a signal generator. There are far too many unbranded chassis makers who are only spoiling the trade and who should be annihilated from the radio field. AWA have taken the reins in their two hands and determined to put on the market something which should stop the public buying cheap, trashy articles which are being offered for sale here, there and everywhere.* It would seem that little has changed in 90 years, except that Australia no longer has its own radio manufacturing companies and must rely on imports – sometimes of quite dubious quality.

⁶ *The Canberra Times*, Saturday 9 January, 1932, page 3.

Sir Ernest Thomas Fisk

Back to 1933, the *Grafton Daily Examiner* went on to report: *The new AWA proposition, commencing with a table model 24 Radiolette, at the astounding price of £13/19/6 [about \$28], is something that is going to make everyone sit up and listen.* While Radiolette was cheaper than the AWA Radiola, it was still a substantial cost, for the basic weekly wage in 1933 was £3/3/4 (about \$7), but even so, Fisk and AWA must have thought they were on a winner. The Fisk Radiolette is still a winner, for a recent perusal of ebay shows one on offer for \$1,750 (discounted from \$1,900).

Image Right: AWA Fisk Radiolette Fret and Foot, 1936.

Source: <http://www.thebakeliteradio.com/page73/page73.html>



1935 & the Wahroonga Memorial



Dec. 14, 1935, Ernest Fisk & former PM Billy Hughes unveil the memorial to the 1st UK to Australia radio transmission in Sept. 1918. The memorial is still outside Fisk's former home. Source: SL NSW.

Fisk and the AWA Factory at Ashfield

Image Right: Sir Ernest Fisk shows visitors the giant radio transmitter at the AWA works at Ashfield in Sydney. Probably circa 1937. Source: State Library of NSW, photo Sam Hood.

Image Below: Sir Ernest Fisk shows the Governor General, the Earl of Gowrie, around the AWA factory in October 1939. This was after the outbreak of WW2, so the woman working on a machine might have been one of many women employed by AWA after the War started.

Source: SL NSW 25192.

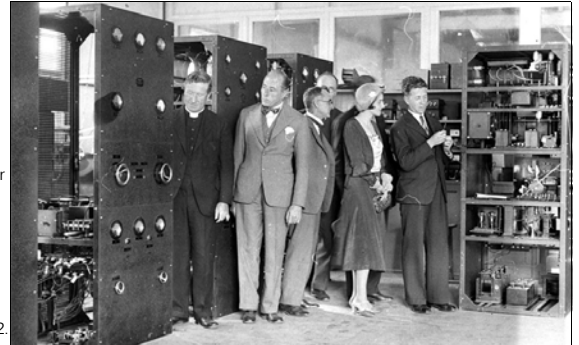

1934 - The first Beam Wireless Picturegram service

The technical innovations of Fisk's *Beam Radio* extended to the *Beam Picturegram Service* in 1934. This assisted in keeping Australians informed of happenings right around the world. For example, thanks to the Beam Picturegram Service, during WW2 newspaper readers could see, within a few hours, photos of world events – the Casablanca Conference, the bombing of the Edersee and Möhne Dams in the Ruhr (the *Dam Busters*), and the blasting of the Rumanian oilfields.⁷

The AWA Building in the City of Sydney

One of Fisk's most visible achievements at the helm of AWA was the construction, from 1937 to 1939, of the AWA Building in York Street Sydney, opposite Wynyard Park, as the new headquarters of the company. As one would expect of Fisk, the building was innovative, distinctive and practical. Its significance has been recognised by its inclusion on the NSW State Heritage Register, which cites: *The AWA Building and Tower is of significance for its important associations with radio and communication technology. It is a simple vertically emphasised skyscraper which represents the epitome of the 1930s desire to integrate architecture with technology. The tower [a steel radio transmission structure on top of the building], for a time was the tallest structure in Sydney, and is an integral part of the building and still has a landmark quality.*



The AWA Building seen across Wynyard Park in circa 1939.

Source: National Library of Australia [nla.pic-an23381789]

Photo by Frank Hurley.

⁷ *The West Wyalong Advocate*, Monday 3 January 1944, p3

Sir Ernest Thomas Fisk

The building was designed in the Art Deco style, which Fisk no doubt chose to signal AWA as a modern, progressive and go-ahead company. Overall, the building is vertically modelled to give a skyscraper appearance but within the rather limited heights allowed in the City of Sydney when it was completed in 1939. As one would expect, the building also reflects Fisk's personality and style. For example, a Pegasus was cast in a relief sculpture on the plain brick parapet at the top of the building. Pegasus, a winged horse, was chosen by Sir Ernest Fisk as a suitable association with the work of Australia's great wireless undertaking. On a more practical level, the building included the Fisk system of double-glazed soundproof windows and ventilators.

York Street was an ideal location for the AWA building to make an impact, for the street follows a ridge and at 112 meters tall the building and tower dominated the then low-lying 1930s Sydney skyline. The tower was 48 metres and at the 97 metre point of the building there was a viewing platform. For many years the tower wore the sign *Beam Wireless*, advertising the service providing radio contact to commercial shipping on the UK – Australia route which AWA had introduced in 1927. The AWA Building remained Sydney's tallest building until the 1960s.

This was not just the head office for AWA, for originally the building housed a number of different uses. A restaurant was located in the basement, the ground floor contained a sales room, major vestibule and Beam Chamber, where the public could dispatch radiograms. The upper floors contained office space (AWA being the major occupier), a radio school and broadcasting studios – a true multi-purpose building with considerable public access and use. In 2000 when AWA ceased operations, the building was sold, but it remains known as the AWA building, although the big red AWA signs have been removed. The tower, which was demolished and rebuilt in 1994, remains illuminated at night and is still a Sydney landmark.

1937 – Ernest Fisk Receives a Knighthood

For his significant services to the development and technical advancements of radio in Australia, Fisk was knighted in 1937. This received widespread publicity in Australia, with, for example, *The Uralla Times* reporting on 20 May 1937: *One of the notable Coronation honours bestowed by the King was that of Knight Bachelor on Mr. Ernest Thomas Fisk, a leading figure in the wireless world in Australia, he being Chairman of Directors of AWA, as well as being identified with other companies. Sir Ernest Fisk has perhaps had more to do with the development of wireless in Australia than most other men.*

However, this was no ordinary knighthood, for two reasons. Firstly, as *The Uralla Times* had noted, this was a Coronation Knighthood, the first such honours bestowed by King George VI, who had only been crowned the week before on 12 May 1937. Such events are rare, so this must have been a special honour for Sir Ernest Fisk, especially with his ties to England. Secondly, it was appropriate that Fisk was honoured with a Coronation Knighthood, for he had contributed to the Coronation. It was Fisk's work and that of his AWA in Australia, that remote part of the then British Empire, that enabled many thousands to hear the broadcast of the Coronation, maybe on their *Radiolas*, which were then the best-known radio receivers in this country. After receiving his knighthood, Sir Ernest Fisk was asked to join several boards, including Standard Portland Cement & Sargents Ltd.

December 1938 – Opening of a New Radio Telephone Service



Images - Clockwise from left:

1. Sir Ernest Fisk conducting the opening of the new radio telephone service in December 1938. Note the microphone on the desk in front of him.
2. At the opening, Fisk introduces former PM Billy Hughes to the service, using the same microphone.
3. Celebrating at a tea party after opening the radio telephone service are (L to R) Sir Bertram Stephens, Premier of NSW, Billy Hughes, Fisk, & unknown. Source (all photos) SL NSW, photographer, Sam Hood.

Sir Ernest Thomas Fisk

A Man Before His Time

Fisk continued to promote the advantages of radio and maintained it was integral to the British Empire, noting: *No scientific discovery offers such possibility for binding together the parts of the far-flung Empire, and for developing its social, commercial and defence welfare.*⁸

Fisk was always looking to the future and what radio could do for humanity. In a radio broadcast in 1935, on *Radio of the Future*, he predicted that wireless waves would eventually be used for heating and cooking. Perhaps this was the first inkling of the modern-day microwave cookers, but he went on to say that they would also play an important part in the cure of diseases of the human body. *Radio waves could be an important diagnostic tool, as they could detect whether the body was vibrating at the right frequency and would be able to give the right frequency at which it should vibrate.*⁹

Strangely reminiscent of current energy debates, Fisk was also a strong proponent of solar power. In 1939 at the first Annual Dinner of the Electrical and Radio Development Association, Fisk stated: *The power of the future is the power of electricity.* Noting that some of the enormous solar energy was being used in water schemes, he asked: *We do not know how to make use of solar energy today but who will say that we shall always remain in this condition of ignorance?* It would seem that 80 years on, 2020 has not seen all of that ignorance disappear, given the current political debates on solar and renewable energy.

Fast forward to 1956 and Fisk still had an engineer's eye to the future, as reported when he arrived back in Australia after a ten-year residence in Britain. He predicted that in 20 years solar power would be used to power home air-conditioners, as the sun provided the *one clean inexhaustible power* and was the answer to many of the world's power problems. This is remarkable, for home air-conditioning was rare in the 1950s, let alone the concept of widespread solar power. In 1956, Sir Ernest also predicted that in 20 years' time television would be in world-wide use and in colour. Again, this is remarkable foresight, for the first television broadcast in Australia was still eight months away and colour broadcasts didn't commence until 20 years into the future.

While the demands of business meant that Fisk's grasp of electronics was quickly being overtaken, the future he painted for wireless was boundless – lighting lamps, cooking the roast, even driving cars. Other sides of Fisk's character are also worth noting:

- He had also been a 'speed demon', establishing 'business driving records' between Sydney, Melbourne and Canberra – obviously before the days of speed cameras.
- Fisk imagined it must be possible to communicate with the dead, especially after the death of his son, Thomas Maxwell Fisk, in an aircraft accident in 1944 while on active service in WW2, and he showed a continuing interest in spiritualism.

EMI / His Master's Voice

AWA continued to grow, reaching a turnover of more than £4 million, and with 6,000 employees by 1944, becoming one of Australia's largest private companies. However, in 1944 Fisk resigned from AWA to become managing director and chief executive of EMI – the Electrical and Musical Industries (His Master's Voice) group in London. This must have been a quite financially rewarding move for Fisk, for he had a salary of £10,000 a year, plus 1½ per cent of net annual profit, compared to A£4,500 a year, plus 2¼ per cent of net annual profit in AWA. Fisk restructured EMI, and profits rose in some areas, including the company's Australian operations. Net profits did decline in 1949 and 1950, and again after 1951. Perhaps by then Fisk was losing some of his cutting edge technology touch, for he resisted EMI's change from 78 rpm to 33⅓ rpm records, even though other companies were going down that path.



Ernest Fisk testing some of AWA's latest receivers at his home, in the mid 1930s.
Source: The Australian Centre for the Moving Image.



Portrait (from left) of: NX95 Lieutenant Colonel Ernest Kelvin Fisk, 8 Divisional Signals; his father Sir Ernest Fisk; and brother Second Officer Thomas Maxwell Fisk, Air Transport Auxiliary.
Source: Aust War Memorial. Photo: Vandyk, London, 1943.

⁸ Quoted in <http://adb.anu.edu.au/biography/fisk-sir-ernest-thomas-6177>

⁹ *Sydney Morning Herald*, Wednesday 3 April 1935, p13

Sir Ernest Thomas Fisk

As he had weakened the firm's long-term prospects, in 1952 EMI decided not to renew Fisk's contract and he left the company, albeit with a life pension of £5000 a year, and a nominal consultancy for five years at £3000 a year. Fisk returned to Sydney as a *consultant in commerce, industry and technology*, and his views were sought on the future of television, which eventually came to Australia in 1956. However, Fisk's main concern in these years was the future of solar, hydro and nuclear power.

The Well-rounded Engineer

Moving away from Fisk's engineering and management career, it is also interesting to look at wider aspects of his life. However, in this case 'well-rounded' definitely refers to Fisk's character and fitness, and not to any aspect of physical appearance. On the business side, predictably Fisk was President of the State Division of the Wireless Institute of Australia, was associated with the NSW Chamber of Commerce, and was a Rotarian and Freemason. However, it was in his non-business life that Fisk's character is really demonstrated. In the early 1920s he was a member of the New South Wales section of the Australian Aero Club; and later vice-president of the Australian Air League. Then he was also involved in the Boy Scout movement, and in 1939 was the inaugural chairman of the New South Wales Council for Physical Fitness and also chaired the Young Men's Christian Association appeal.

Perhaps unusually (but very commendably) for an engineer, Fisk had a strong interest in the arts and music. At a meeting of the Musical Association of New South Wales in 1936, he stated: *Wireless is the servant of art and particularly of the art of music. Music is the universal language at present and wireless carried that language to every country.* And he did put this interest into practice, being a patron of the Music Teachers' Alliance and the Royal Philharmonic Society of Sydney. Even in retirement, Fisk still enjoyed singing. It was a wonder that he had time for his 'proper job' in AWA, but this does demonstrate his boundless enthusiasm and extremely wide ranging interests – which do mesh in quite nicely with his engineering and business life.

It was also reported that in retirement, Fisk continued to enjoy champagne for lunch and was a member of the Union and Australian clubs, Sydney, and the Royal Sydney Yacht Squadron. Even with all these interests, it was reported that he still swam daily. Indeed, it would appear that in keeping with his character, Fisk was quite active until near the end of this life. Newspaper reports noted that until only six months before his death, Fisk rode his bicycle daily across the Sydney Harbour Bridge, and this does line up with my sightings of him around Roseville.

This was certainly in line with the motto on his coat of arms, *mens sana in corpore sano*, which translates as *a sound mind in a sound body*. This is surely a fitting motto for any engineer: definitely of sound mind and fit – ready for any task or situation that may be confronted or created.

Sir Ernest Fisk died on the 8th July 1965 at his home in Roseville, Sydney, aged 78, after a long illness. Reports in the newspapers of the day described him as *the colourful pioneer of radio and electronics in Australia*, noting that he helped establish the formation of radio communication throughout the world. His reputation was certainly world-wide, for even the New York Times reported the next day under the heading *Sir Ernest Fisk Dies at 78; Australian Radio Pioneer*.

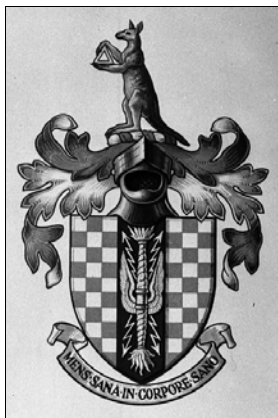

Fisk's Coat of Arms, adopted by AWA. Source: SL NSW.

Acknowledgements:

Australian Dictionary of Biography
Trove - for its great store of newspaper articles and journals
State Library of NSW
Australian National Portrait Gallery



Sir Ernest Fisk: 'citizen of the world of tomorrow', in *People Magazine*, 17 January 1951.
Source: State Library of NSW.



This image of the 1935 memorial outside Fisk's former Woollahra home appeared in a booklet prepared for the occasion. The memorial is still in situ, but alas, the statuette of fleet Mercury has gone. Source: State Library of NSW.

Anthony George Maldon Michell, F.R.S.

Inventor of the famous tilting pad thrust bearing.

By Stephen Phillip

In the first decade of the twentieth century, the world's shipping industry found itself in a crisis. The powerful steam turbine engine was gradually replacing the piston engine, and propeller designs were becoming increasingly efficient. However, ships also require a special bearing to transfer the enormous thrust generated by the propeller to the ship's hull. Existing designs of these thrust bearings were hopelessly inadequate and prone to catastrophic mechanical failure. This technological problem was causing terrible difficulties and appeared to be insoluble.



Image from a biographical memoir of A.G.M. Michell, by T.M. Cherry, published by the Royal Society.

The severity of this situation was particularly acute in Australia; separated by vast distances from England and Europe, it was heavily reliant upon shipping for both the export of raw goods such as meat and wool, and the import of finished goods, including machinery. It is therefore entirely appropriate that the solution, an entirely new concept in marine thrust bearing, was developed by the young Australian engineer Anthony George Maldon Michell. Michell became a world expert in hydraulics and a prolific inventor whose creations, of which the tilting pad thrust bearing is only one, revolutionised the world of industry and engineering. He possessed a rare quality of having both a keen mind for the theoretical aspects of engineering, and the practical skills to make working products based on the theory.

Michell was born at Islington, London, in 1870 while his family were visiting England. The family returned to their home in Maldon, a small gold rush town in the colony of Victoria, and Michell spent his early years there. His family moved to Melbourne in 1877, where he attended the State Primary School in South Yarra. In 1884 the family returned to England for a time, where Michell became a student at the Perse Grammar School in Cambridge and later attended lectures at Cambridge University.

In 1890 Michell returned to Australia and attended the University of Melbourne, attaining a Bachelor of Engineering in 1895 and Master of Engineering four years later. He commenced work as a consulting hydraulic engineer, initially as an assistant to Bernhard Smith – one of his lecturers at the university – but soon after he established his own business. Michell was also the consulting engineer to Geo. Weymouth Pty Ltd, Electrical Engineers, of Richmond in Melbourne¹, and in this capacity helped the company design and manufacture equipment for many of the irrigation development projects being implemented along the Murray River.

By his early thirties Michell had already created three new inventions - a regenerative pump, a cross-flow turbine², and a water meter.³ This remarkable achievement is a testament to his creative mind. Each of these devices enjoyed moderate commercial success, and many were installed in irrigation schemes around the country.

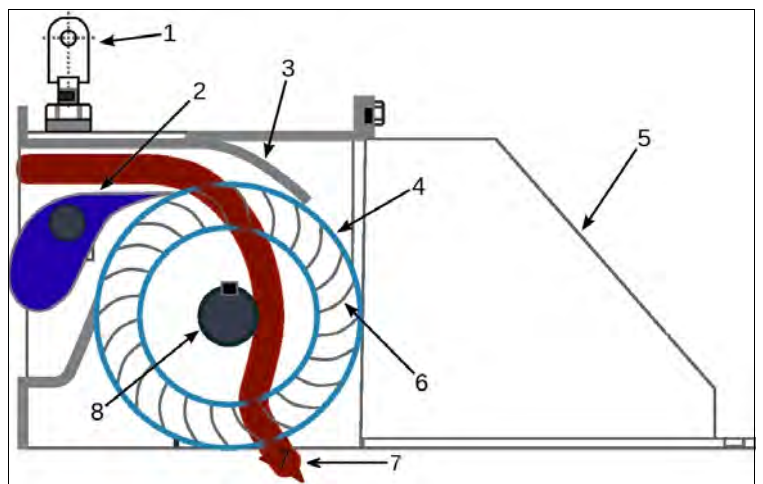

Diagram of a cross-flow turbine – adapted from a Wikipedia image (see footnote 2). Key: 1 = air-venting valve; 2 = distributor (blue); 3 = turbine casing (thick grey); 4 = runner; 5 = removable rear casing; 6 = blades; 7 = water flow (red); 8 = shaft.

His most significant invention however was the tilting pad thrust bearing. He became aware of the serious deficiencies with existing thrust bearings through his extensive experience with water pumps and turbines, which require a bearing to absorb the thrust which is developed along the length of their shaft when running.

1 See <https://collections.museumvictoria.com.au/articles/3075> for an article by Matthew Churchward about Geo. Weymouth Pty Ltd.

2 A cross-flow turbine is described simply in https://en.wikipedia.org/wiki/Cross-flow_turbine

3 At <https://trove.nla.gov.au/newspaper/article/74854461#> a letter titled *Water by Measure* dated 9 Oct 1908, from AGM Michell to the Editor of *The Cultivator*, discusses the merits and use of his (Michell's) water meter.

Anthony George Maldon Michell, F.R.S.

The existing designs were plane-faced collar bearings, in which flat collars attached to the shaft made contact with fixed plane shoes. When a load was applied to these bearings the lubricant between the fixed shoes and moving collars was squeezed out, allowing the parts to come into direct contact. As a result of this the bearings often experienced high friction, causing them to overheat and eventually seize.

The spark of inspiration came to Michell when he read a technical paper written by Osborne Reynolds⁴, *On the Theory of Lubrication and its application to Mr Beauchamp Tower's experiments*. Several years previously Tower had tested many different configurations of journal bearing (a type of bearing which supports the side load on a shaft), and found that some performed much better than others. Reynolds' paper contained a mathematical analysis of the lubrication of a journal bearing, and was able to explain the test results. It concluded that bearings are able to sustain considerable thrust loads only if the lubricating oil between moving and stationary components is able to take on the shape of a tapered wedge. The wedge of oil supports the thrust and prevents metal to metal contact.

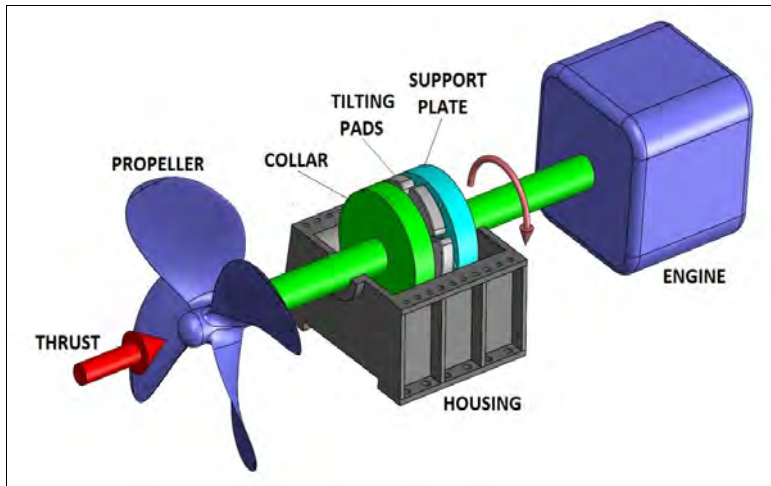

Three Diagrams of a Michell Thrust Bearing. Rotating thrust collar & shaft are green; static support plate (attached to the housing) is blue; tilting pads are grey.
Source: All three diagrams are from Stephen Phillip.

Michell realised that he could invent a new configuration of thrust bearing which utilised this principle of a tapered wedge of oil. To achieve this configuration, he arranged six sector-shaped pads in a ring around the shaft. Each pad is stationary relative to the rotating shaft, but rests on a support on which it can pivot. By doing this it can tilt at a small angle relative to a collar which is attached to the shaft.

The whole assembly is enclosed in a housing filled with oil. When the bearing is first set in motion, the pads pivot on their support so that the gap at the front (leading edge) is larger than the gap at the rear (trailing edge). This forms a wedge shape filled with oil between pads and collar. For the bearing to work properly a continuous supply of oil is needed at the front edge of each pad.

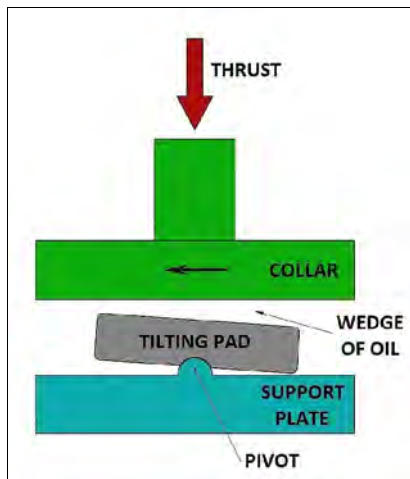

The pivot, shown in section here, appears as a ridge on the exploded view of the support plate (see image at right),

The hydraulic oil pressure developed in the wedge resists axial thrust, eg from a ship's propeller, and transfers the force to the non-rotating tilting pads which in turn transfer the thrust via the pivot ridges into the support plate, the bearing housing and eventually to the ship's hull. The pivot allows the pad to self-adjust to the optimum angle, including zero angle (flat or parallel with the support plate) at low or zero rpm of the rotating shaft and collar, when the engine is almost stopped, or just starting.

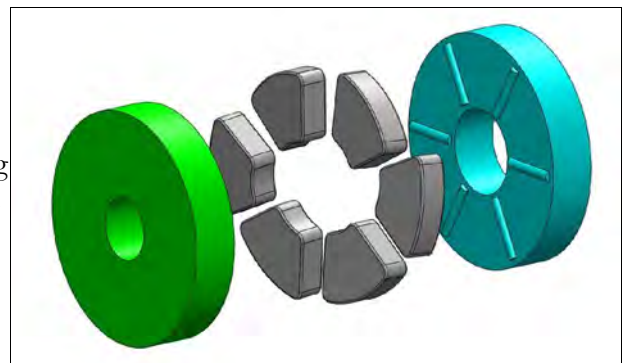

Exploded view of the Mitchell Thrust Bearing.

In tackling the problem of the thrust bearing, Michell employed the methodical process which he used to solve all of his technical challenges. First he conceived the general physical layout of the bearing. He then developed a mathematical model of it, and derived the equations which defined its operating capabilities. Finally, he constructed a prototype and conducted experiments on it to verify that the performance matched the theory. From the mathematical model of his new thrust bearing, Michell was able to calculate the load it could support and its frictional losses. Compared to existing bearings, his new bearing could support 10 times the thrust load of previous bearings and with just 1/20th of the previous frictional loss.

⁴ Osborne Reynolds FRS (23 August 1842 – 21 February 1912). A British engineer, physicist, and educator best known for his work in hydraulics and hydrodynamics. He was Professor of Civil & Mechanical Engineering at the University of Manchester.

Anthony George Maldon Michell, F.R.S.

Michell obtained British and Australian patents for his new tilting pad thrust bearing in 1905. He did not obtain a US patent, a mistake that he came to regret in future years because the American engineer Albert Kingsbury subsequently invented and patented a similar product.

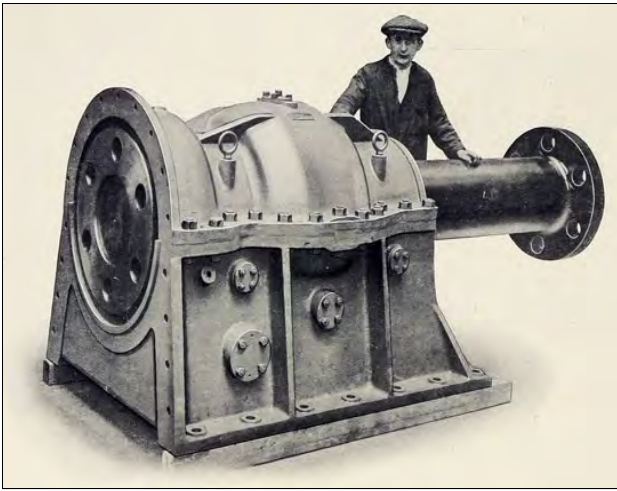

Michell Main Thrust Block Type 'C'. Source: Grace's Guide.

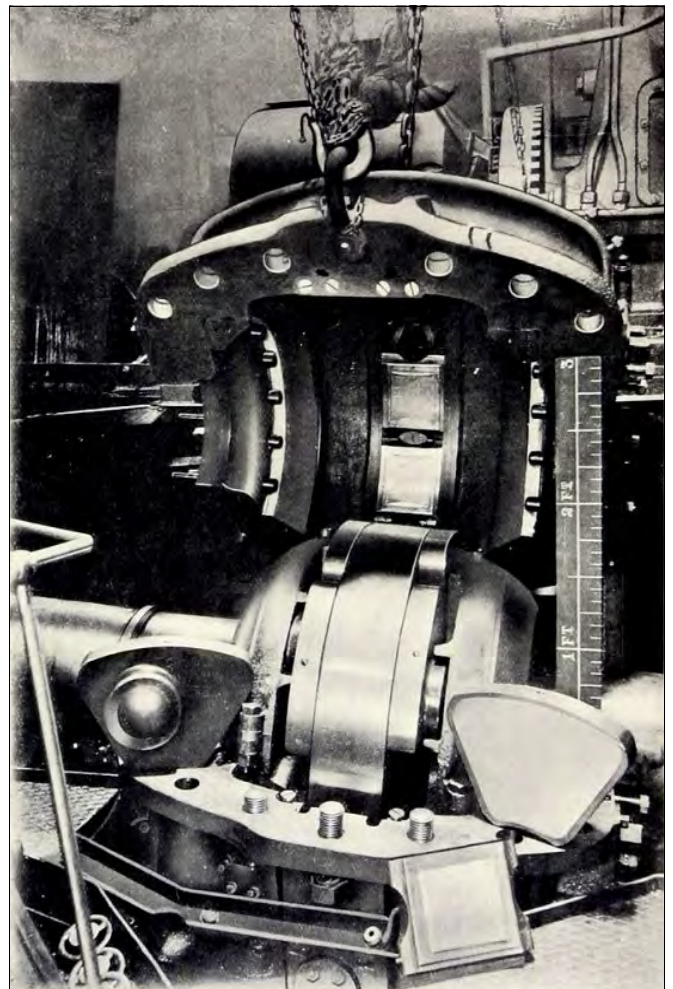

Michell combined marine thrust block & journal bearing, M type, fitted to HMS 'Mackay'. Note the double-sided bearing, presumably to allow the ship to go astern, or reverse. Source: Grace's Guide.

Some Installations

COMPLETE PUMPING PLANTS
VICT. STATE RIVERS AND WATER SUPPLY COMMISSION:—
 Cohuna Head Works — 40,000 gallons per minute, 18 feet lift.
 Swan Hill 40,000 gallons per minute, 18 feet lift.
 Koondrook—40,000 gallons per minute, 18 feet lift.
 Nyah—9500 gallons per minute, 95 feet lift.
 White Cliff—19,000 gallons per minute, 95 feet lift.

SYDNEY SEWERAGE — 2 15h.p. Electric Motors and Pumps.
MT. LYELL M. and R. COY.—200h.p. Winding Engine and 345h.p. of Electric Motors.
LONG TUNNEL MINING CO.—1 200kw. Generator, 3 45h.p. Mine Pumps, 1 75h.p. Supply Water Pump.
COCKS PIONEER ELEC. TRIC G. and T. SLUIC. ING CO.—1 330kw. Generator, 4 100h.p. Electric Motors.



Three-Phase Motor and High-Lift Turbine Pump.

Complete Installations for
Lighting, Haulage, Mining,
Pumping, Driving, Ventilating.



Reg. Office and Works.

G. WEYMOUTH,

Electrical Engineers

This section of a George Weymouth advertisement shows the Weymouth factory and a Michell turbine pump as used in the installations listed at left, including along the Murray River. Source: the Museum of Victoria.

In 1907 an opportunity arose for Michell to trial his new bearing in a commercial application. The first installation was in a number of new centrifugal water pumps at the pumping station in the town of Cohuna, near the Murray River in Victoria. The pumps and bearings were manufactured by Geo. Weymouth Pty. Ltd., Electrical Engineers of Richmond, Victoria, and these were a complete success when put into operation. The bearing soon became very popular in land based applications. Within five years dozens of companies around the world were producing large quantities of the bearing under manufacturing licence agreements with Michell.

However, the enormous potential market of the shipping industry remained elusive for many years, because highly conservative marine engineers were reluctant to try such an innovative product. They could not believe that such a 'ridiculously small' device could sustain such high loads, and indeed a leading British engineer of the time scoffed that "Even if it is successful, I cannot see any field for it."

Anthony George Maldon Michell, F.R.S.

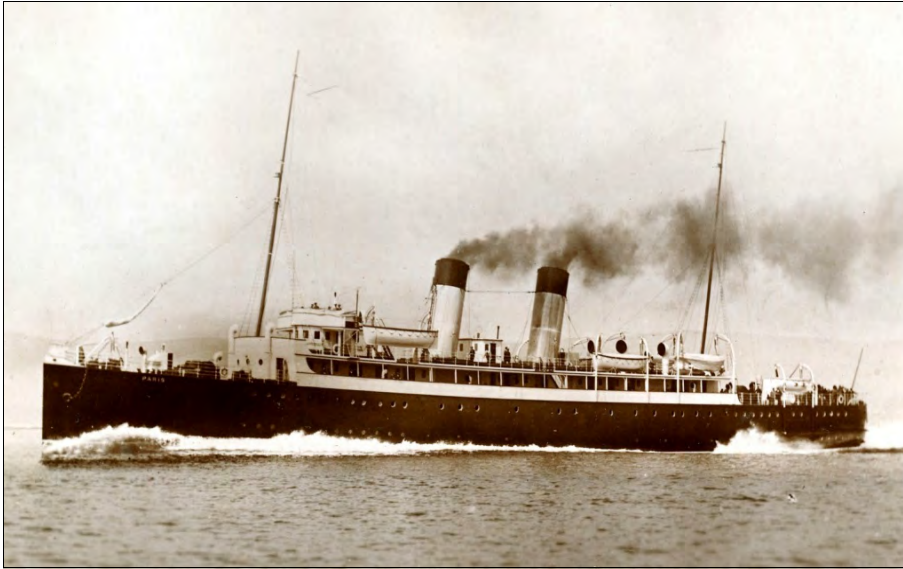

Cross Channel steamer TSS 'Paris', the first ship in the world to be fitted with the Michell Tilting Pad Thrust Bearing.
Source: Stephen Phillip.

The breakthrough finally occurred in 1913, when the cross-channel steamer *TSS Paris* became the first ship in the world to be fitted with Michell thrust bearings. *TSS Paris* was built by the shipbuilding firm Denny's, of Dumbarton on the Clyde, was powered by two geared turbines each of 10,000 horsepower, and had a top speed of 23 knots. Each propeller generated a thrust of 24 tons which was supported by a single Michell thrust bearing. The sea trials of the *TSS Paris* were so successful that within a year Michell's bearing was universally specified on all ships built in British shipyards, including those for the Royal Navy.

Vice-Admiral Sir George Goodwin, engineer-in-chief of the Royal Navy, said of the Michell bearing: *The true principles of lubrication, so long known but not utilised, have now been applied in a manner which can properly be described as revolutionary.* Regarding their application to ships, he said: *The practical solution of the problem has been effected by Mr. Michell in no uncertain manner and it has been adopted unreservedly in the Navy with complete success.* The enormous success of the tilting pad thrust bearing catapulted Michell to world fame. His elegant and remarkable solution to the perplexing problem of thrust bearings ensured that, at least for a while, his name was well known in engineering circles.

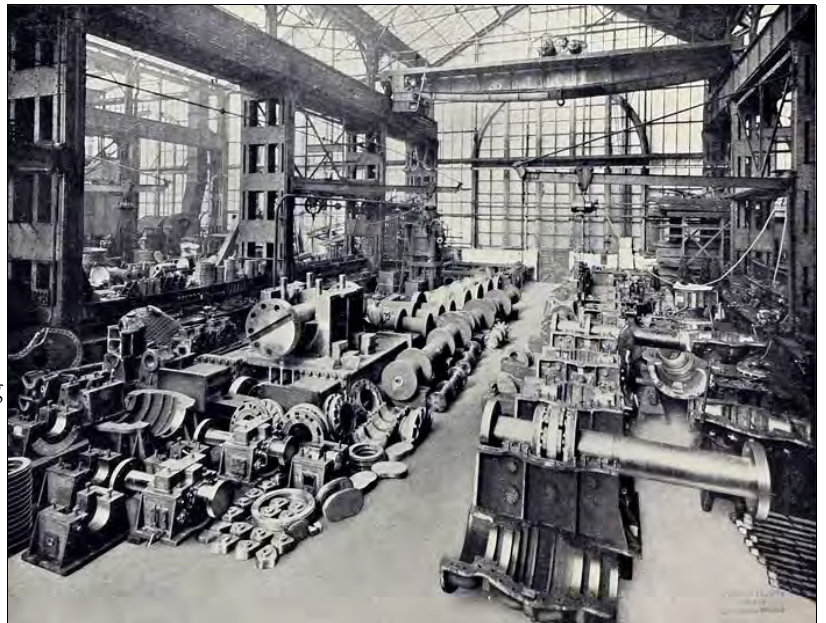

Michell marine thrust blocks, for Diesel engines & standard ships, under construction at Messrs Vickers' Works, Barrow, 1919.
Source: Grace's Guide.



Michell Bearings Ltd. works, Sth Benwell, Newcastle-upon-Tyne.

Source: Grace's Guide.

In 1919 Michell's thrust bearing patent was due to expire. He made a formal request to the British High Court of Justice for a time extension, citing the long delay in the bearing's implementation in the ship industry. Michell provided compelling evidence and the Royal Navy supplied an endorsement, such that a seven year extension was granted. The following year, Michell and his business associate Henry Newbiggin established the Michell Bearing company in Newcastle, England.

Anthony George Maldon Michell, F.R.S.



Early days at the Newcastle UK Michell works, showing the production line for the Thrust Bearings. Image printed in a 1920s Michell Bearings catalogue. Source: Stephen Phillip.

The Michell Bearing company began producing large numbers of thrust bearings for use in ships and land based applications. These were sold to all countries of the world except for those in North and South America, where Michell's rival Kingsbury sold thrust bearings under his own patent.

Michell maintained an active interest in the welfare of the company which bore his name, but did not involve himself in its operations. He politely declined requests to assist with running the company, primarily because he did not consider himself a businessman. He believed that the main ongoing challenges for the company were to increase sales and consolidate the manufacturing process, and in neither of these did he consider himself an expert. The company is still in operation and remains one of the world's leading suppliers of the tilting pad thrust bearing.

No story about Michell would be complete without mentioning another of his inventions, the crankless engine, which absorbed much of his time and energy in the period 1920-1932. In the Michell crankless engine the pistons are oriented parallel to the drive shaft, and engage with a thick disc (called the slant) which is attached to the drive shaft at an angle. Michell established the Crankless Engines (Australia) Pty. Ltd. company in Melbourne. More than 50 prototype engines were manufactured at its workshop in the suburb of Fitzroy, for a diverse range of applications including for automobiles and aeroplanes.

Michell installed a crankless car engine into a Buick, and arranged for it to be taken to America and demonstrated to both Ford and General Motors.

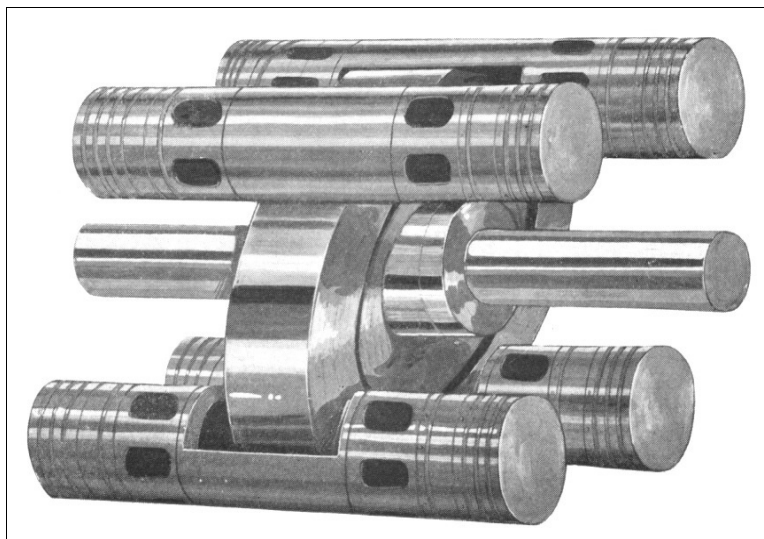

This image/diagram of a crankless engine is taken from the 'Handbook of the Michell Crankless Engine', printed by the Crankless Engine company in 1927. Source: Stephen Phillip.



Staff of Michell's Crankless Engines (Australia) Pty. Ltd. lined up for a photograph outside the Fitzroy workshop of the company, sometime in the mid 1920s. Source: Stephen Phillip.

While both companies were impressed with its performance, and agreed that it was more efficient than their equivalent production engines, they did not adopt the crankless engine. The crankless design was compact and efficient, and worked equally well when run as a compressor.

The George Waller company in Stroud, England took out a manufacturing licence, and produced more than 100 crankless compressor units for the British gas industry. Technologically the crankless engine was a remarkable innovation, however it was not ultimately accepted by industry.

Anthony George Maldon Michell, F.R.S.

In 1942 Michell was the recipient of the highly prestigious James Watt International Gold Medal, which is awarded by the British Institution of Mechanical Engineers (IMEchE) for outstanding contributions to mechanical engineering. Michell was unable to attend the presentation ceremony in London as World War 2 was in progress,



however he was able to listen to a direct radio broadcast of the proceedings which had been specially arranged by the BBC. In presenting the award Professor Andrew Robertson, vice president of IMechE, described the Michell bearing: *Few inventions have provided so complete a solution to an engineering problem, and it belongs to that small class in which there is little scope left for further practical development.* Indeed, the tilting pad thrust bearings manufactured today are remarkably similar to Michell's original design.

In 1950, at the age of 80, George completed his 'magnum opus', the textbook *Lubrication - its Principles and Practice*. Published by Blackie of London, it deals with the mathematics of fluid flow, lubrication of surfaces, and the practical application of lubrication theory to the design of machinery.

Image Left: An advertisement placed by Michell Bearings Ltd., advising that it would have a stand at the forthcoming 1929 North East Coast Exhibition (a World Fair held in Newcastle, UK). More than 4 million people attended this Fair. Source: Stephen Phillip.

Michell died in 1959 at his home in Camberwell, in which he had lived for 62 years.

In 1964 a new building for Civil Engineering was officially opened at the University of Melbourne. Within this building is a laboratory devoted to the study of hydraulics, named the *Michell Hydraulic Laboratory* in honour of AGM Michell. T.M. Cherry, Professor of mathematics at Melbourne University said of Michell: *He had the introversion that is natural to a thinker, but he had also the positive feeling that adults should conform to serious standards, and that to be taken seriously a man should pass the hard test of being completely sincere.*

A.J. Francis, Professor of civil engineering at Melbourne University wrote: *Rarely in the history*

of engineering can theory and practice have been so happily blended as in the person of Anthony George Maldon Michell. He wrote as he thought, with precision, clarity, and deep mathematical insight.



This photo of the plaque in the Michell Hydraulics Laboratory was taken by Stephen Phillip.

To perpetuate the memory of Michell, the Mechanical College of Engineers Australia awards the AGM Michell Medal each year. This award is presented for outstanding service to mechanical engineering. Professor John Crisp, who received the award in 1984, described Michell as *arguably Australia's most versatile Engineer*.

On occasion George Michell used the motto *Theory is the captain, practice the soldiers* which precisely and succinctly described his approach to tackling engineering problems. Michell was a genuinely modest man, who regarded his theoretical work as his primary achievement. His contributions, both theoretical and practical, remain a fascinating and vitally important part of Australia's engineering heritage.

Select References *Biographical Memoirs of Fellows of the Royal Society, AGM Michell*, Vol.8, 1962.
Modest Man of Genius – AGM Michell & the Crankless Engine, Sydney Walker.
A Gentle and Unassuming Man, Derek Ravenscroft.
The Life and Work of AGM Michell, LK Stevens, 1970.
Men of Tribology, Prof. Duncan Dowson, Jnl of Lubrication Technology, Jan.1980.
The Michell Thrust Block, JH Gibson, Trans. Inst. of Naval Architects, Vol.61, 1919.



This photo of AGM Michell & a pear tree is from Melb. Uni. Archives.

Die Wuppertaler Schwebebahn

From the Editor, Margret Doring.

Sometime in 1989 we received a letter from our daughter Jessie, who was living near Dusseldorf at the time, in which she told us about the Wuppertal Suspension Railway, on which she took a ride. She went to Wuppertal with a good friend she knew from Dusseldorf, who told her about the elevated train and that she should experience it. Here is a transcription of her letter:

“Woke up in Wuppertal (about 20-30 km away). The person I was with escorted me back to Dusseldorf to Ritchie’s via the Schwebebahn (!) and the train. Maybe Simon [Jessie’s brother] told you of the Schwebebahn? I don’t know. Firstly I must explain the geography of Wuppertal. It is a town built in a valley with a long river (now dead) at the beginning of the mountains. So the town/city is only at most 1 km wide, ½ each side of the river and 3 km at the most further up the river, so most of the people, when they go to work, travel up or down the valley on the Schwebebahn. [There is no room for a normal railway in the valley so] to overcome the transport problem, almost 100! years ago they built the Schwebebahn, which is a suspended railway/tram that is built over the river. The tram/trolley cars are connected to rails above the tram like the picture. It is an all iron (?) construction and very, very, very impressive to see, but the people on them look like anybody anywhere bored by it all! If only they knew what a strange life they live. It can go quite fast and swings out as it goes around bends. You can see right below yourself the river, and near the end it leaves the river and travels a bit on land where you are above cars and people! Piles more impressive than that joke in Sydney the Monorail. It looks impossible. I will photograph it for you both.”



Die Wuppertaler Schwebebahn and the River Wupper in 1992. The original passenger cars were joined together by chains, allowing them to traverse very tight bends. The modern cars are joined like Sydney’s bendy-buses, with a concertinaing cladding down the sides and at top and bottom. Photo: M Doring, 1992.

Her photographs never eventuated, but we were so fascinated with her account, that we visited Wuppertal ourselves in 1992 and took some photos – of the railway and Depot Oberbarmen . I didn't think about it much for years, and then we received the February 2006 issue of *Industrie Archäologie* (a Swiss publication, in German, edited by our friend Oskar Baldinger¹) in which the Schwebebahn is the cover story. That renewed my interest in the Schwebebahn. By then, some genius had invented the Internet, and another one invented Google, so I set out on a hunt for more information.

The only thing I found then was not via Google, it was a paper photo-copy of a story titled *The Mono-Railway Systems* which appeared in the *New South Wales Railway Budget*, of September 7th, 1901 and I can’t remember where my copy came from. How amazing that a story about the Schwebebahn appeared in an Australian Magazine, so far away, so soon after it was built.



Map of the Wuppertaler Schwebebahn, as it existed in 2006.

Fecit Pechristener in Wikipedia.

¹ Alas, that Magazine is no more. Oscar died in 2015, and I published an obituary of him in the June 2015 issue of EHA Magazine

Die Wuppertaler Schwebebahn



Side View of Suspended Railway following the course of the Wupper.

The image at Left appeared in my copy of the NSW Railway Budget story as a rather coarse photocopy of what was probably a very detailed photograph. Nevertheless it was still worth reproducing, with its clear view of the electric motors and the curve of the line following the river.

The *NSW Railway Budget* story starts with an account of the “Behr” type of mono-railway and its predecessors, and then goes on to discuss suspended railway systems, as follows:

“The suspended mono-railway system was used as far back as 1821, when a Mr. Palmer constructed such a line for the transportation of goods by means of suspended cases and baskets; animal power being used to work the line. Variations of the system were used at one time and another in England and America; a similar device was also in use on the Thames goldfields in New Zealand in the early seventies [the 1870s]

to bring quartz across deep gullies to crushing machines. It was, however, left to a Mr. Eugen Langen to perfect the system as seen in the suspended mono-railway between Barmen and Vohwinkel in Germany.

Continuing from the NSW Railway Budget:

“Briefly speaking the “Langen” type is an electric, elevated, single rail line, carried by iron girders, the car body being freely suspended from the wheels which run above on the rail; the use of guides is entirely avoided. Trials have proved that the free suspension of the cars and the possibility of swaying without influencing the safety are the principal advantages of the suspended railway. During the trials even the most violent winds had no appreciable effect on the stability of the cars, nor could the passengers succeed in swaying them. It is only when going round curves that the cars incline, which is, however, not noticed by the passengers, as they also, naturally, occupy the same position.

“Among the advantages claimed for this type of rail road are :- The steadiness of the cars does not depend on the uniformity of the gauge, the packing of the rails, &c., as in the case of the ordinary permanent way. It is possible to take the line through fairly narrow streets, and it adapts itself to their sharpest bends with ease. There is no necessity of slackening speed when the train is rounding curves, as the cars accommodate themselves to the sharpest curves with safety.

Image Right: This drawing of Elevation, Plan & Section of the Schwebebahn comes from a 1904 German dictionary of technology. The Section shows the River Wupper and the elevation shows the Antrieb (motive power) being the electric motors above the rails.

Source: Wikimedia.

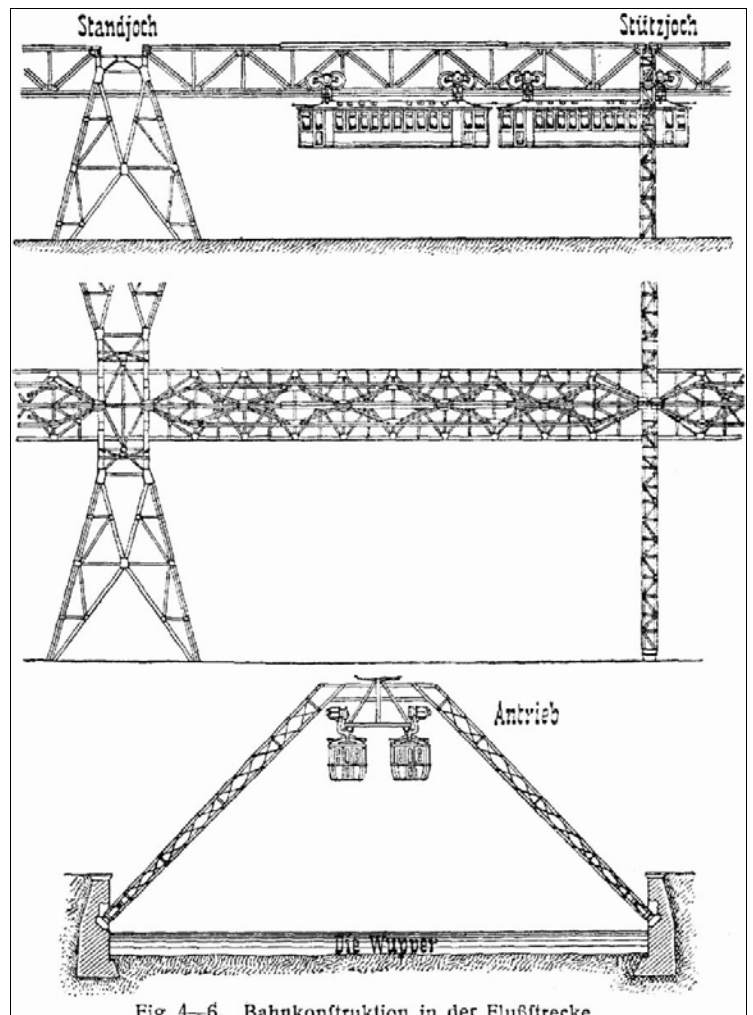

Fig. 4-6. Bahnkonstruktion in der Flußstrecke.

Die Wuppertaler Schwebbahn

Continuing from the NSW Railway Budget:

“Derailment is absolutely impossible, nor can the rail be detached from the girder above it by any accident; and there is almost an entire absence of vibration. Owing to these advantages, and the high speeds that can be attained, this type of railway adapts itself well to long distance traffic, especially where quick transit is an important factor.



Image Left: This sign appeared after another accident which could not have been imagined in 1900 – a mobile crane driving along Sonnborner Strasse ripped the underbelly from a passing train! The sign is bolted to a portal frame of the Schwebbahn.

Source: Atamari in Wikimedia.



Derailment is absolutely impossible?? The above image shows the “Aftermath of the 12 April 1999 derailment of a Wuppertal Suspension Railway train, the result of track-maintenance equipment not being removed from the line before the resumption of normal traffic”. Image: By “Pillbox” from Wikimedia.

“One of the disadvantages of the system is the inability of passengers to leave the cars in cases of stoppages from any cause between platforms. But this can be overcome, the line being double, by bringing a car up on the other line and transferring the passengers, who would, of course, have to make a return journey to the next platform. But it is said that such contingencies would very rarely arise owing to the construction of the line, and interruptions of long duration on both lines at the same time are impossible, owing to the electrical arrangements that have been made for the supply of power.



Employees of construction companies pose for a souvenir photo in 1898 as part of a carriage was suspended in a station.

Image: from the Schwebbahn history website (see footnote 4).



Inside the Doeppersberg station in circa 1901. The No.1 car awaits passengers.

Image: from the Schwebbahn history website.



A view of the interior of a typical carriage of the series built circa 1900.

Image: from the Schwebbahn history website.



This 1898 construction photo appears to show a type of travelling truss, with hoists projecting from each side, being cantilevered forward to lift the next A frame into place. The framework built up from the river bed is for construction of a station. Note the eager spectators along the river bank at right.

Image: from the Schwebbahn history website.



The station at Alter Markt in 1903.

Image: from the Schwebbahn history website.

“In the competition for the construction of the city proposal, Barmen-Elberfeld-Vohwinkel, towards the end of 1894, Langen’s type of suspended railway carried off the victory; but, owing to legal procedure, work could not be commenced until 1897; at present [1901] it is the only suspended single rail line which carries passengers. A section was opened for traffic in 1899; but the first principal section, 4¾ miles in length, is to be opened for traffic during the current year; the whole line, 8¼ miles, to be completed in two years’ time.

Die Wuppertaler Schwebebahn

Continuing from the NSW Railway Budget:

“The line starts from the Barmen railway station, follows the river Wupper through the towns of Barmen and Elberfeld, leaves the Wupper at Sonnborn following the main street into Vohwinkel, where it terminates near the Government railway station. The present maximum speed is limited to 31 miles per hour, which will give, including 18 stoppages, an average speed of about 24½ miles per hour. The maximum speed can be attained in from 10 to 15 seconds after starting.



The Oberbarmen car depot, at the east end of the Schwebebahn line. This was a maintenance workshop and held the rail loop where the trains turned back to Vohwinkel. The Oberbarmen passenger station is to the right, out of the picture. Photo: MJ Doring, 1992.



A 1913 postcard by Werther Bollwerk, showing the Schwebebahn above the river Wupper.

Source: Wikipedia.

“The line is carried throughout its length by iron girders; those along the river Wupper are placed in pairs opposite each other, resembling in shape the capital letter “A” but with the apex cut off, as shown in our illustration [also see page 25 of this story above]. It may be remarked here that the river has a width of from 46 to 124ft.

“In the streets of the towns the supports are portal shaped, leaving the streets entirely free for vehicular traffic, while the vertical supports on either side occupy but little more space on the footpaths than ordinary lamp posts. All platforms are on the outer side of the rails (double line) being mostly about 15 feet above the road.

“All vehicles are motor cars; each car is suspended from two two-wheeled bogies 8 feet apart; the wheels are double flanged. Each car holds 50 persons, but sitting accommodation is provided for 30 only. At present the traffic is carried on with single or double cars, as may be required, but the stopping places are arranged for trains of four cars. The absolute block system, which has been adopted, allows of a two minutes service. Four classes of brakes are used, viz. the Westinghouse Air Brake, a hand brake, and two electric brakes, one of which is used in emergencies only.

“As this type of rail way can be easily adapted to any local conditions, it is anticipated that it will ultimately be introduced into cities where it is desired to connect two or more important points by means of an efficient and speedy service.” [End of extract from NSW Railway Budget, 1901]

Image Left: Shows the portal frame supports where the Schwebebahn passes along the Kaiserstrasse near Vohwinkel. Source: Wikipedia - Photographer Andreas Schaefer, 4th October 2007.



Die Wuppertaler Schwebebahn

The writer of the Railway Budget story was wrong in predicting the wide introduction of this rail system in the future – it never happened. But the Wuppertaler Schwebebahn is still going strong, and has even been extended a bit in length and new stations have been added over the years since 1901.



A train waits to leave Oberbarmen. From Wikimedia, Photo - Bahnfreund, 26 Apr 2016. This is the place where we started our trip. This photo substitutes for my dark, fuzzy version, but it is the same type of car, a GTW 72 that we rode in. Each carriage has two suspenders (or overhead bogies). Each suspender has an electric motor driving a pair of wheels.

My diary says: . . . To [Oberbarmen] Wuppertal in evening. Travelled by suspended train to the far end of the railway and back again to Berliner Platz at the [Oberbarmen] train shed end. Had dinner at a Greek restaurant near the station. Remarkably, the Greek restaurant was owned by an Aussie, of Greek extraction, and we had a long chat about our distant homeland.

Oberbarmen Station (above) is somewhat altered from 1992, but the train is identical except for paintwork and a number (ours was car No.1). We were interested in recording the suspension system and the motors. How did it work? It appeared somewhat top-heavy. How were they certain it wouldn't fall off the rail? Well the incident I showed on page 26 was the only serious accident ever to happen on the line. *The Wuppertal Schwebebahn accident took place on 12 April 1999 on a stretch of track near Robert-Daum-Platz station. In this accident involving car number 4 from the WSW GTW 72 series, five persons lost their lives while 47 were injured, some of them seriously.*²



We can compare the motor and suspender systems on the GTW 72 trains with the only 1900 train to survive to this day – the Kaiserwagen, still running when the very last GTW 72 trains have retired: *It was this carriage in which Kaiser Wilhelm II and his consort Augusta Victoria of Schleswig-Holstein rode when they visited Wuppertal on 24 October 1900. Both the carriage, and the overall suspension-railway system, have been designated protected monuments since 26 May 1997.*³

Image Left: Detail of the motor and spoked wheels of the 1900 Kaiserwagen.

From Wikimedia. Photo: Atamari, 14 November 2015

The arrangement of the motor relevant to the wheels is quite different from the GTW 72 motor, with the Kaiserwagen motor's shaft transverse to the direction of travel. The connection between motor and wheels is unclear in this photo.

On the 11th April 1992 we (Carl and I) made our long projected visit to Wuppertal. We had been travelling in a campervan in a big circle around northern Europe (Switzerland, Austria, Czechoslovakia – as it was then – and Germany, from East to West. And there we were in Nordrhein-Westfalen, camping outside a friend's house (the Ritchie mentioned in Jessie's letter) in Dusseldorf. We spent the morning shopping in the "dorf", drove by Bochum to visit a mining museum – it was closed – and finally, stupidly, reached Oberbarmen im Wuppertal in the early evening, too late for more than two or three reasonable photos.



Detail of a suspender, motor, worm gears, wheels & brake (top right) of a GTW 72 carriage.

Wikimedia photo - Matthias Bohm, 13 Nov 2015
Again, this photo substitutes for very poor ones we took.

² See https://en.wikipedia.org/wiki/1999_Wuppertal_Schwebebahn_accident

³ See <https://en.wikipedia.org/wiki/Kaiserwagen>

Die Wuppertaler Schwebebahn



Image Above: The two cars of the Kaiserwagen. From Wikimedia. Photo: TeWeBs, 6 August 2018.

Image Right: Passengers wait for the Kaiserwagen to emerge from Vohwinkel Depot. It will switch to the main track further along the station. Note the non-load-bearing live rail to the right of the girder. Return current goes back through the wheels into the load-bearing rail on top of the girder.

From Wikimedia: Photo: Atamari, 5 July 2013.



The Kaiserwagen and another 1900 carriage were restored in the 1970s to make a two-car tourist attraction which circles from Vohwinkel to Oberbarmen and back in about an hour. The passengers are seated at little tables, and served with tea and cakes, or perhaps something harder later in the day. The driver (above) is seen dressed in a formal blue uniform. The ride is apparently very popular, and a money spinner for the City Council.



A modern train going around the tight loop at Vohwinkel.

From Wikimedia. Photo: Atamari, 5 July 2013.

Apart from the unique progression above the river, there are a few other places along the route that stand out. The turning loops at each end are amazingly tight – so tight that I wonder how the Kaiserwagen handles them. The photo (at left) shows a modern train passing around the Vohwinkel loop, like a super Sydney bendy bus.



The structure of the Vohwinkel turning loop, clearly showing the live rail inside the loop. From Wikimedia. Photo: Mabit1, 2 August 2020.



The original Doeppersberg station (Hauptbahnhof on the map). Photo circa 1903. Image: from the Schwebebahn history website.

A few stations I found interesting - a fertile field for architectural fancies. Many of them changed over the years. One of the grandest, the Art Nouveau Hauptbahnhof



Oligsmuehle station, opened 1982. From Wikimedia. Photo: Oktaeder, 31 May 2004.



The Kobo Building that replaced the original Doeppersberg station in 1927. From Wikimedia. Photo: Geolina 163, 8 September 2012.

at Doeppersberg, had a complete transformation in 1927 when a large barn-like office building (or perhaps a factory?) suddenly swallowed up the Schwebebahn, the trains and the river below in its maw, and spat them out on its other side. Some stations, like Oligsmuehle, became aggressively Post Modern in their transformation, but still fitted well with the railway structure.

Die Wuppertaler Schwebebahn

One early photo (right), which purported to show the Schwebebahn under construction at Sonnborn in 1900 (although it already had a train suspended from it), showed the Schwebebahn overhead truss diving under the brick arch of a railway bridge, over which a steam train hauling goods wagons passes. The river passes under the next arch, and a roadway under the next again.

In modern photos, the same place had been transformed, with a totally different Sonnborner Eisenbrücke spanning road, river and Schwebebahn. When did that happen? The answer came with a postcard painting from 1914, obviously by the same hand as the postcard on page 27.



Construction of the Schwebebahn at the Sonnborner Eisenbahnbrücke in 1900.
Image: from the Schwebebahn history website.



The crossing of 3 rails at the new [railway] bridge in Sonnborn – 1914. From Wikimedia, which states: Unknown author – from the private collection of Wolfgang Sauber..

And in this image (left), the roadway has a tram on it – hence the three rails crossing. The new bridge is said to also be a brick structure, but the flat arch shown is quite unrealistic – artistic licence no doubt. Here (below) is what it really looks like – now – much taller and with a new parallel roadway across the river.



Eisenbahnbrücke over the Schwebebahn. From Wikimedia. Photo: Atamari, 28 December 2008.



View from the 19th floor of the Sparkasse Tower in Wuppertal.
From Wikimedia. Photo – Frank Vincentz, 31 August 2008.

I particularly liked this semi-aerial photo (at left). The Schwebebahn looks like a many-legged goanna, sticking his head into the Kobo Building at Döppersberg Hbf – but then he pops out the other side and disappears along the river.

The plaque at right shows Eugen Langen, the inventor of the Schwebebahn.
From Wikimedia.
Photo – Atamari, 24 Feb, 2018
Possibly located in Döppersberg Hbf (Kobo House)

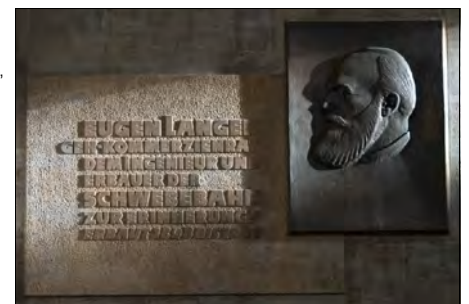

Die Wuppertaler Schwebebahn



Three generations of trains together! Kaiserwagen and a GTW 72 model salute the arrival of the first GTW 15 in Wuppertal on 14 November 2015.

From Wikimedia. Photo by Matthias Böhm, 14 November 2015.

The trains would be built in Spain, and the first one arrived in Wuppertal by truck, to great ceremony, on 14 November 2015 – *At 11:15 a.m. precisely, the first new suspension railway carriage was delivered to Vohwinkel. An emotional moment that was honoured by the residents of Wuppertal with a huge celebration.*⁵

We never had time to return to the Schwebebahn, to tour the depot, examine carriages and machinery, talk to operators, and take many photos. So, when I decided to write this story, I turned to the Internet. And what a treasure trove I found – particularly in Wikimedia Commons, which has a series of hundreds of images of many aspects of the Schwebebahn. There was also a website⁶ with a chronology of the railway's history, which answered many of my questions. It had some (small) photographs reproduced above, which were the only early (pre WW1) images I found there. There are virtually no readily accessible photographs from the 1920s through to the 1980s, so let's hope there's another treasure trove of B&W film somewhere, buried in some German archive, waiting to be found and scanned and annotated and uploaded to the Net. However, these days, we have moving images on line to enliven our memories. Jessie found this: <https://www.youtube.com/watch?v=AaDDd4Rixi4> and there are lots more where it came from. I found this: <https://www.youtube.com/watch?v=DgfRq4kEFro> which took me for a ride in the driver's cabin, all the way from Vohwinkel to Oberbarmen and back again – long drawn out but so real I was in there with the driver. I could even see the Sonnborner Strasse trams (Page 30) were no more.

Judging by the many recent photographs of the Schwebebahn to be found, it is obviously hugely popular with, and highly valued by, the German public these days. It was a different story 30 years ago – back then it seems to have been something of little interest, hidden away in an obscure backwater. I wonder was it even known at all outside the Wupper valley. We visited Germany with a raft of introductions and recommendations for visits to all sorts of Industrial sites, but not one mention from anyone of the Schwebebahn. I hope this story inspires some of our readers to pay it a visit – the next time they go to Europe!



And now for the last two photographs (I hope you're not saying thank goodness) and a very small joke. They show the New Generation GTW 15 at work, very recently.

Image Left: The rear of a GTW 15, from Wikimedia, photo Stephan Sandrock, 12 June 2020

Image Right: The front of a GTW 15, from Wikimedia, photo "Wuppertaler" 30 April 2020.

Masks are de rigeur these days!

By 2010, the fleet of GTW 72 trains were nearly 40 years old, and beginning to show their age. The city decided to commission a complete new fleet, with all the latest developments in motors and electronic controls. On 10 November 2011 the city Stadtwerke – *signed a contract at the Vohwinkel suspension railway workshop, for the construction of the new suspension railway with the Düsseldorf-based company Vossloh Kiepe.*⁴



Its motors accompanied the first GTW 15 train in another truck. Here they are displayed on their truck in a nearby park.

From Wikimedia. Photo by Rheinbahnfan, 14 November 2015.



4 See <https://www.schwebebahn.de/en/history-technology/history/>

5 *ibid.*

6 *ibid.*

